

All rights reserved. Copyright infringement will be prosecuted.

PHOMI®
econicly



Art Stone

「Redefining building materials: Customizable textures X Programmable patterns X Infinite colors.」

PHOMI HOLDING
material science that shapes the future



www.phomi.com

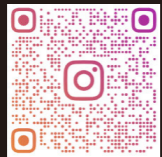

instagram

Tel: +86 13928802403
Email: sales@phomi.com

2025.7

Founder/leader/standard setter of MCM industry
Winner of the 123rd Paris International Invention Gold Award
Winner of the 76th International Exhibition of Inventions Nuremberg
Winner of Chinese Patent Award

A New Formula for Stone: Zero Carbon, Infinite Design.

Global Hub for Rare Stone Digitalization

PHOMI eCovering Smart Plant



PHOMI is transforming the building envelope industry with four core innovations: low-carbon materials, pioneering aesthetics, integrated photovoltaic technology, and cost efficiency.

As a disruptor of high-carbon building materials, PHOMI's products replace natural stone, tiles, precast concrete, and synthetic resin. By combining solar power and digital technology, PHOMI creates a "triple evolution path" for building envelopes: supporting municipal renewal, zero-carbon buildings, infrastructure upgrades, and aesthetic redesign. It provides a photovoltaic building-integrated (BIPV) energy system and a digital information platform.

This dual innovation in materials and functionality transforms building envelopes into smart, energy-efficient, and information-rich systems, reshaping the construction industry's value chain.

Certified for 18 consecutive years by international authorities with on-site inspections, rigorously tested in extreme climates from polar cold to equatorial heat, our products demonstrate proven reliability across 120 countries worldwide, achieving a global application milestone with over 60 million square meters of implemented solutions.



1 **eCovering**
A Digital Collection of Art Stones
from Across the Globe

2 **eSolarFacade**
Partner with the Sun to power the buildings on

3 **eDisplay**
Turn the stone into a 24/7 premium
advertising space

4 **Negative Ion Series**
Integrated with nano-level negative ion technology, redefining
architecture with a perfect fusion of health and aesthetics



From the Burj Khalifa Tower to Starbucks, 237 landmarks are rewriting the oxygen formula for 300,000 m² commercial spaces with eCoverings.

Globally rare, ultra-large 1200 x 6000mm seamless stone slabs, perfectly showcasing natural voids.

「Masterfully crafted geological textures, perfected with millimeter precision」

「Each oversized art stones embodies the relentless pursuit of perfection」

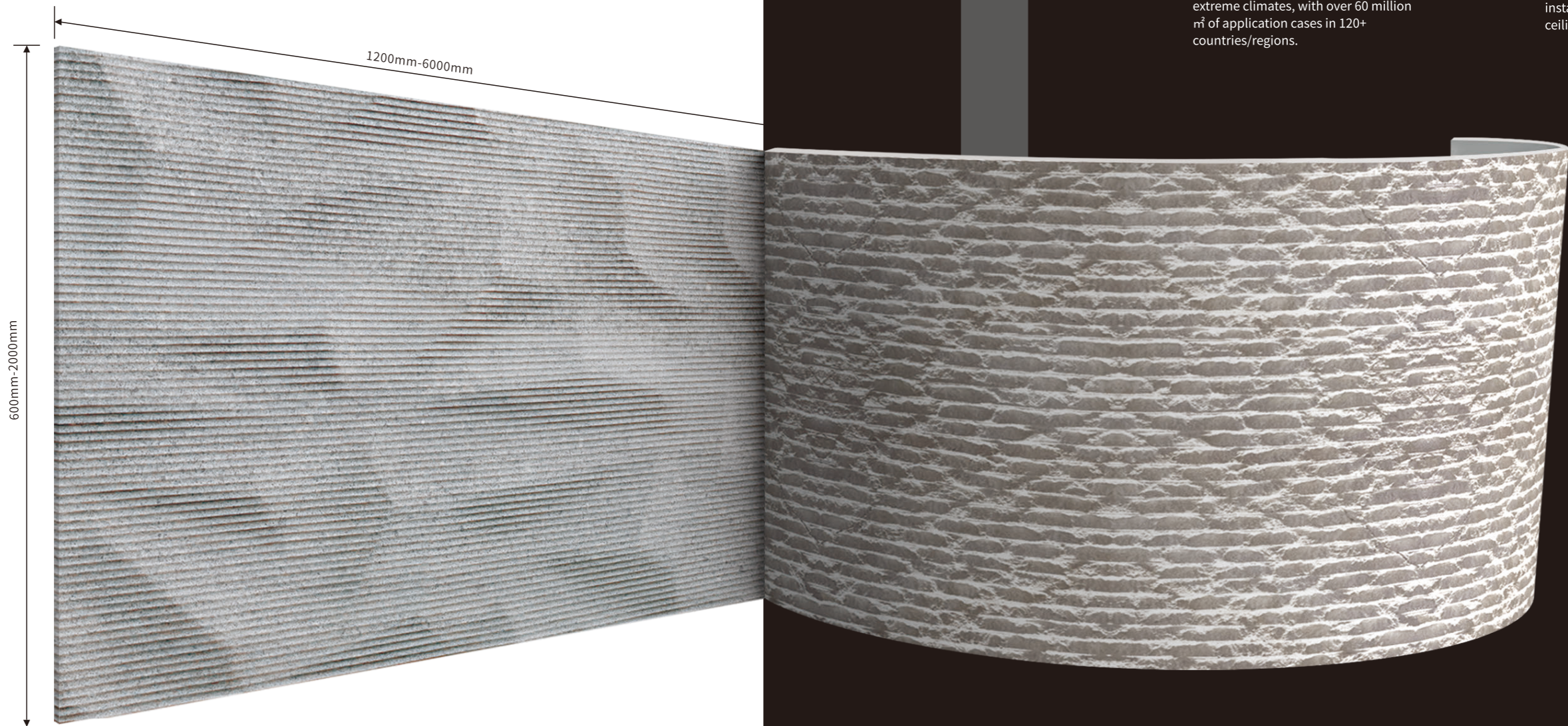

Why PHOMI eCovering?



Authentic modified clay, from nature. Without resin, no toxic ingredients, Healthy.



A-class fireproof, mold and bacteria-resistant. (optional)



Inorganic material without resin, 50-year weather resistance, anti-fading. Applied for 18 years under various extreme climates, with over 60 million m² of application cases in 120+ countries/regions.



Versatile applications: salt spray resistant, freeze-thaw resistant, breathable, lightweight, and easy to install; suitable for irregular shapes, ceilings, bathrooms, and more.

Shape It Your Way,
Limitless Possibilities

 eCoverings reduce compared to tiles **↓95.4%** CO₂e

 eCoverings reduce compared to stones **↓98.63%** CO₂e

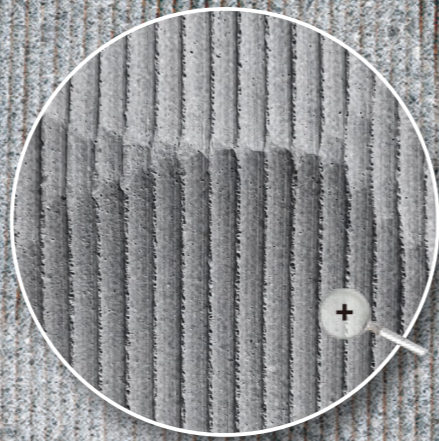

Every detail tells the Earth's low-carbon story.

Nile Warm Grey

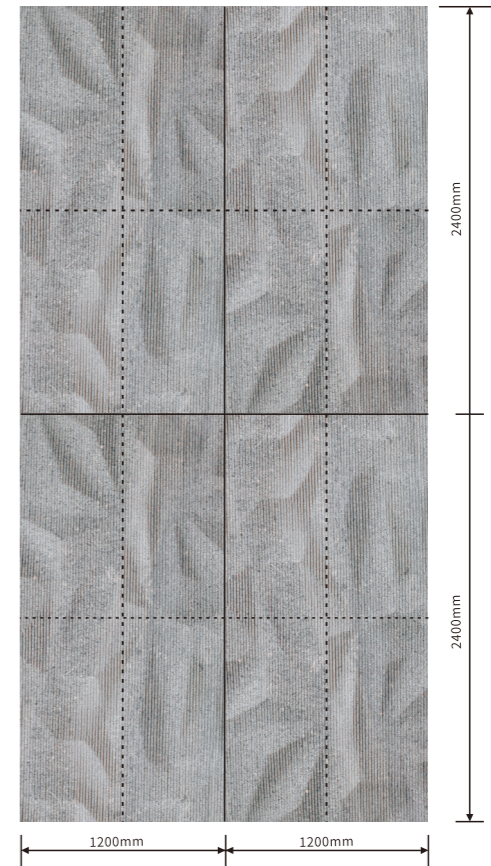

More color options



Specification and packaging

Generation	Standard Size (mm)	Thickness(mm)	Packaging(mm)	Pcs/box	Sqm/box
3.0	1200 x 600	1-9	1220x620x75	8	5.76
	2400 x 1200		Sizes above 2400x1200 are packed with wooden case as per order quantity (subject to packaging fee)		

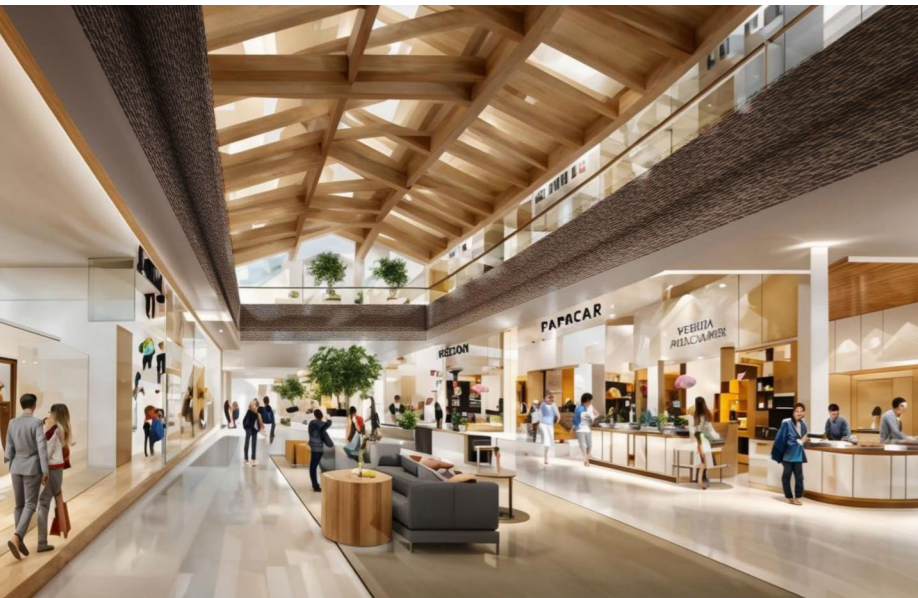

Prediction: In the next decade, all stores will be part of eCovering systems.

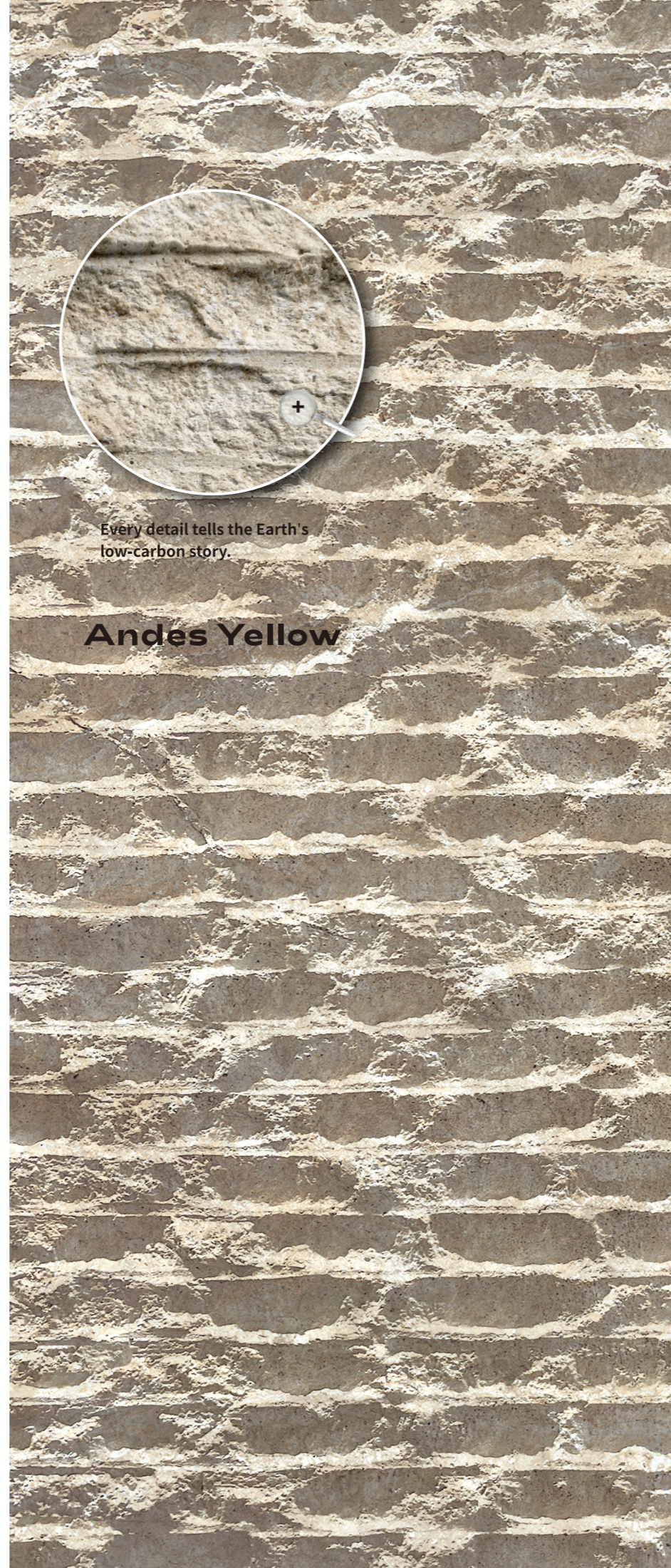

Every detail tells the Earth's low-carbon story.

Andes Yellow

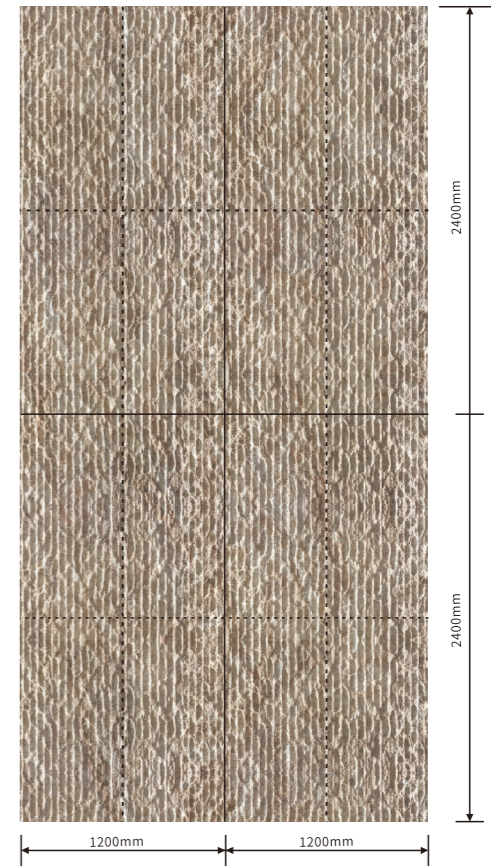

More color options



Specification and packaging

Generation	Standard Size (mm)	Thickness(mm)	Packaging(mm)	Pcs/box	Sqm/box
3.0	1200 x 600	1-7.5	1220 x 620 x75	8	5.76
	2400 x 1200		2420 x 1230 x14	2	5.76

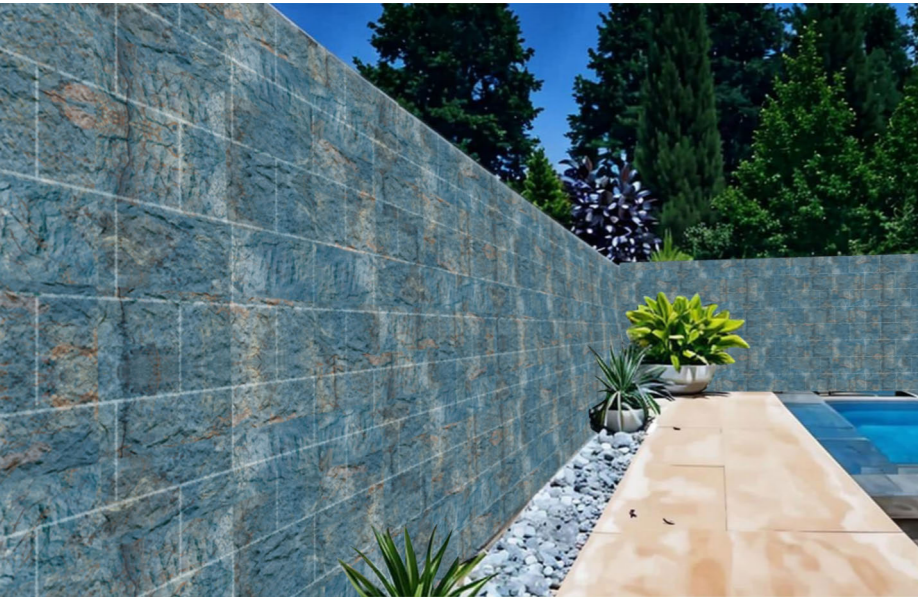

An Ecological Poem in Stone, a Zero-Carbon Sanctuary in Rock Light.



Every detail tells the Earth's low-carbon story.

Multi-Color Rust

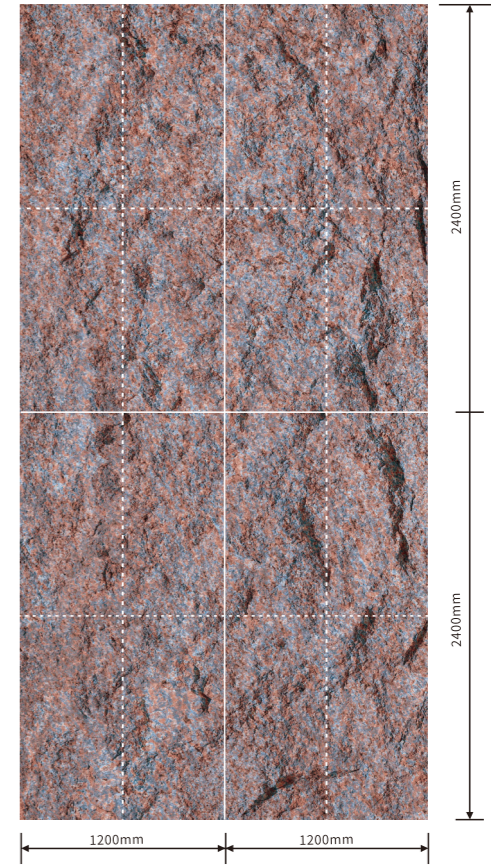

More color options



Specification and packaging

Generation	Standard Size (mm)	Thickness(mm)	Packaging(mm)
3.0	800x400	1-8 natural unevenness	Sizes above 2400x1200 are packed with wooden case as per order quantity (subject to packaging fee)
	1200x600		
	2400x1200		

Geological Stone Collection: A Carbon Sink Story of Stone and Light.

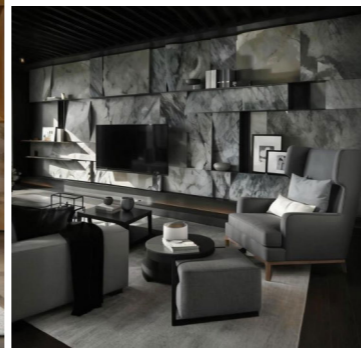

800X400mm



800X800mm 300x300mm

From Mines to Curtain Walls: Hidden Cost Visualization Report

For a 100,000m² project, PHOMI art stones delivers savings of:
 Transportation: 533,560 USD → 373,215 USD (saving 1.5 million USD)
 Packaging Loss: 525,266 USD → 82,936 USD + zero insurance claims (saving 442,329 USD)
 Carbon Tax: 5.21 million euros saved (based on EU CBAM 2026 at 90 euros/ton)
 Project Timeline: 3x installation efficiency, reducing capital costs by 2.9 million USD
 Total Savings: 8.5 million USD in reduced costs, with IRR increasing to 22.7%

More color options



Specification and packaging

Generation	Standard Size (mm)	Thickness(mm)	Pcs/box	Sqm/box
3.0	800 x 400	1-10 natural unevenness	72	23.04
	800 x 800		40	25.6
4.0	300 x 300			

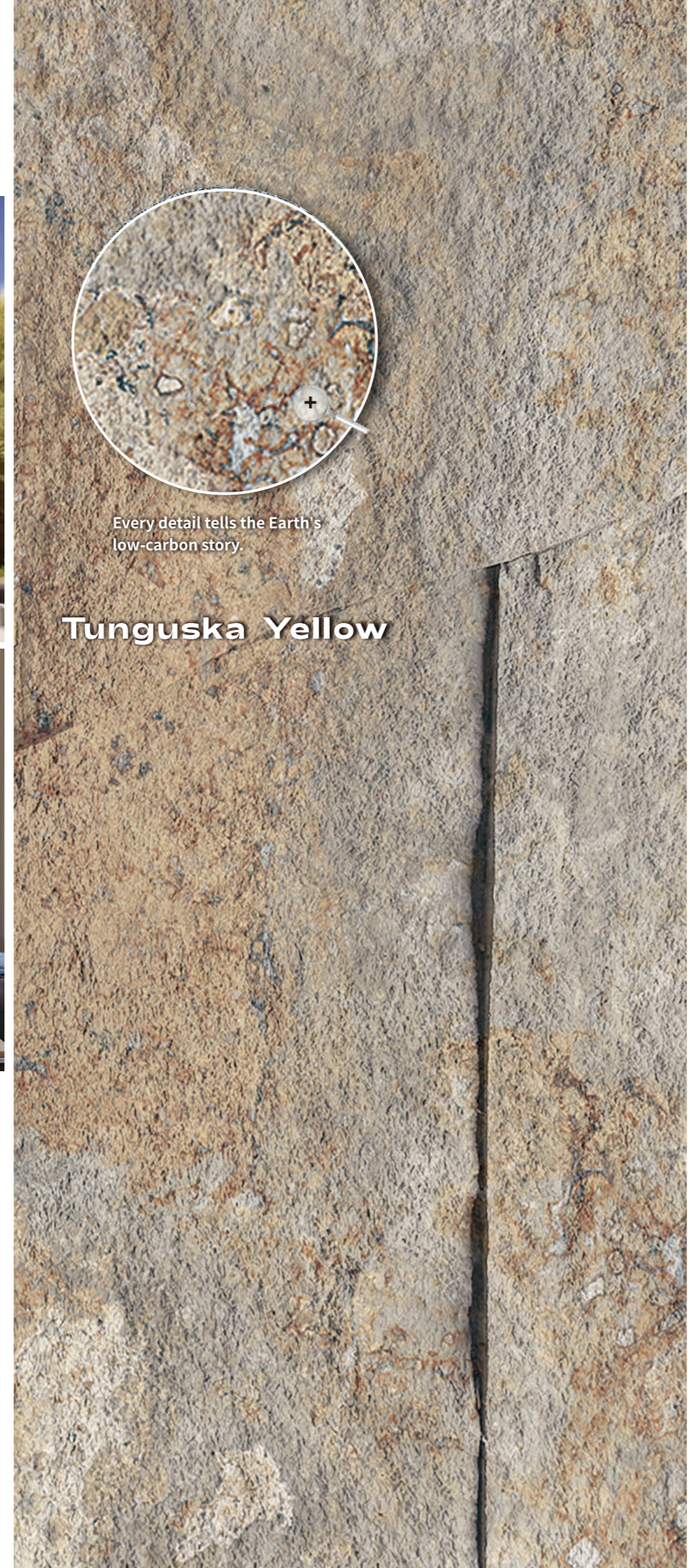

Every detail tells the Earth's low-carbon story.

Tunguska Yellow

Elevating Environmental Protection from Ethics to a Technological Revolution

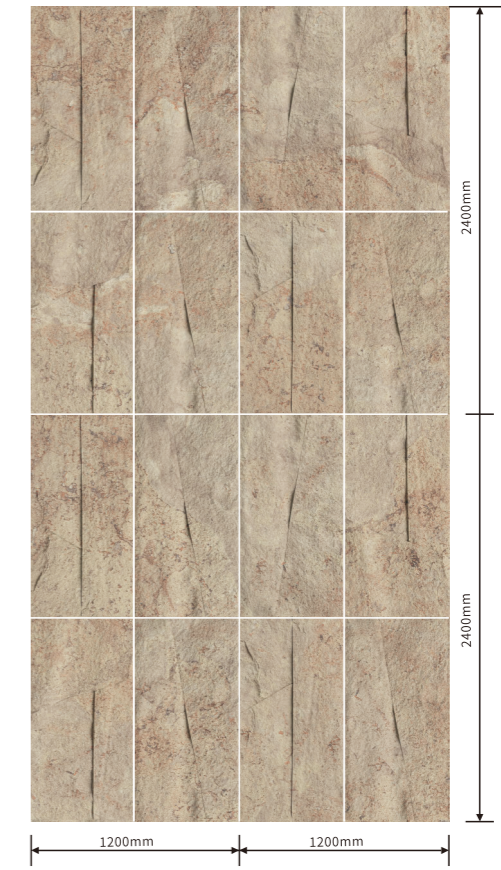

More color options



Specification and packaging

Generation	Standard Size (mm)	Thickness(mm)	Packaging(mm)	Pcs/box	Sqm/box
3.0	1200x 600	1-8 natural unevenness	1220x 620x75	8	5.76
	2400x 1200				

Sizes above 2400x1200 are packed with wooden case as per order quantity (subject to packaging fee)



Every detail tells the Earth's low-carbon story.

Castle Rock Grey

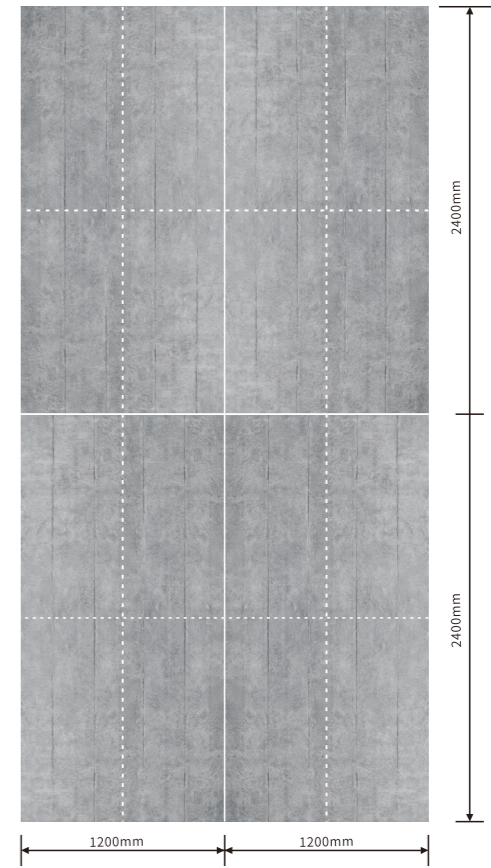

More color options



Specification and packaging

Generation	Standard Size (mm)	Thickness(mm)	Packaging(mm)
3.0	1400 x 600	1-3.5	Sizes above 2400x1200 are packed with wooden case as per order quantity (subject to packaging fee)
	2800 x 1200		



When building materials heal the Earth, humankind will understand its wounds.

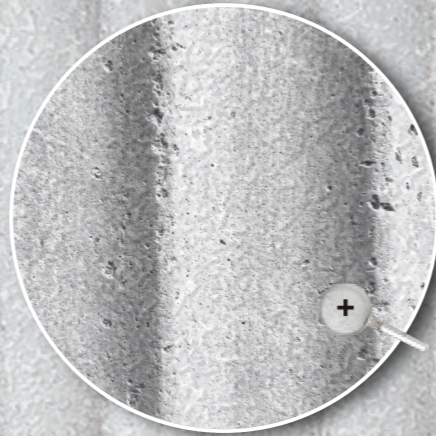
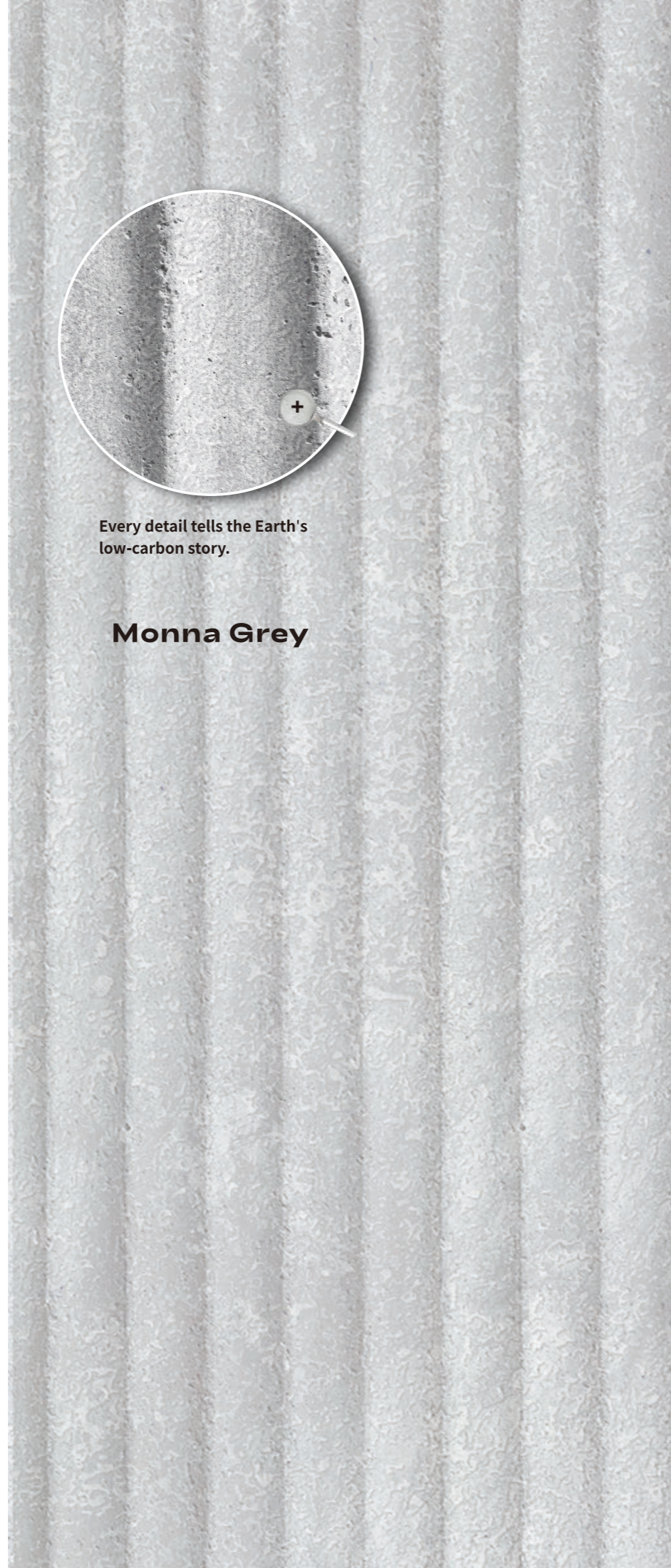

Every detail tells the Earth's low-carbon story.

Monna Grey

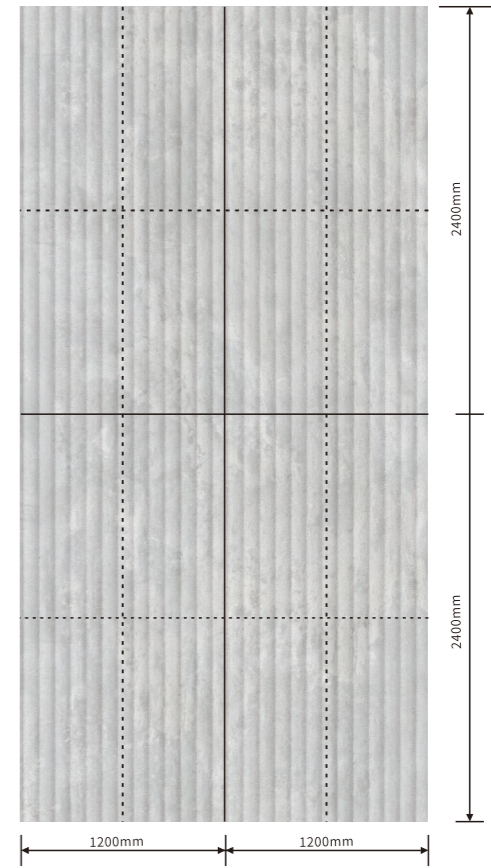

Specification and packaging

Generation	Standard Size (mm)	Thickness(mm)	Packaging(mm)	Pcs/box	Sqm/box
3.0	1400 x 600	1-8 natural unevenness	1420 x 620x75	12	10.08
	2800 x 1200				

Sizes above 2400x1200 are packed with wooden case as per order quantity (subject to packaging fee)



Every breath of a public building should ease the Earth's burden.

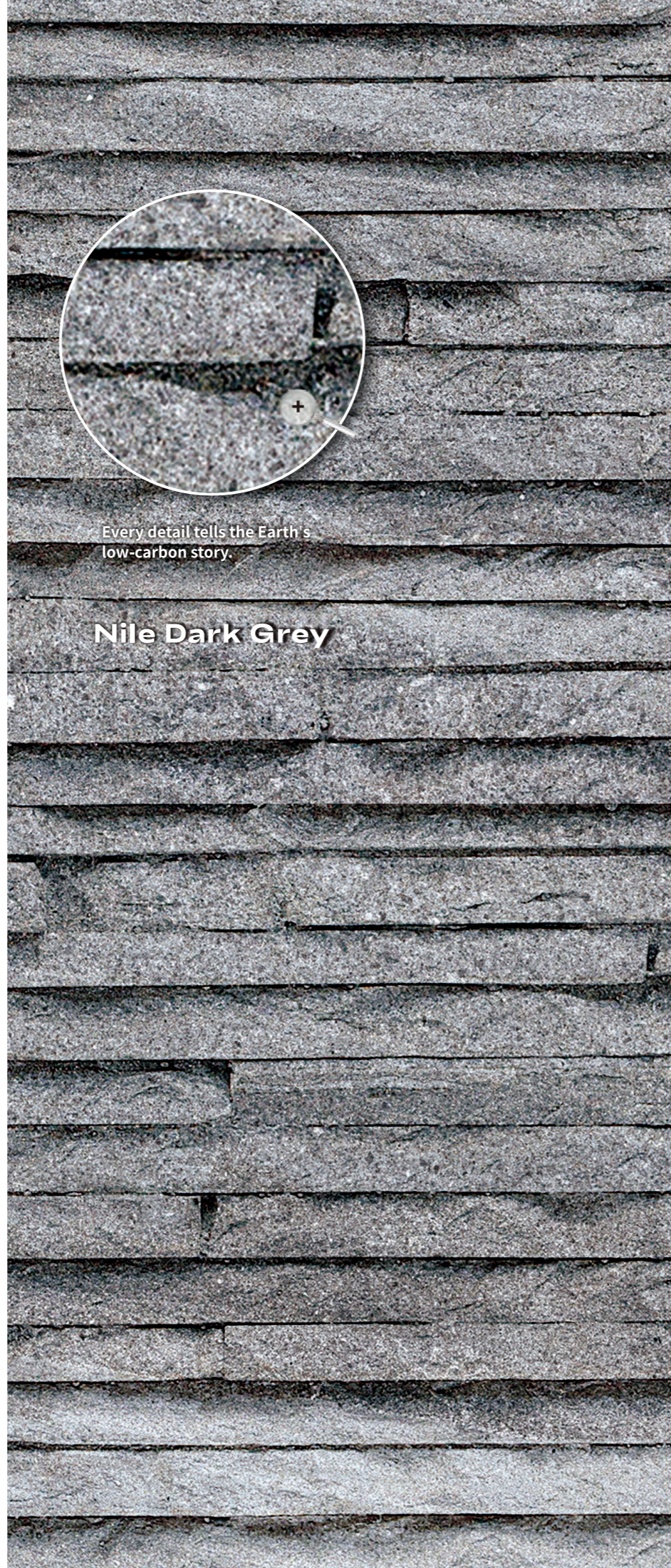

Every detail tells the Earth's low-carbon story.

Nile Dark Grey

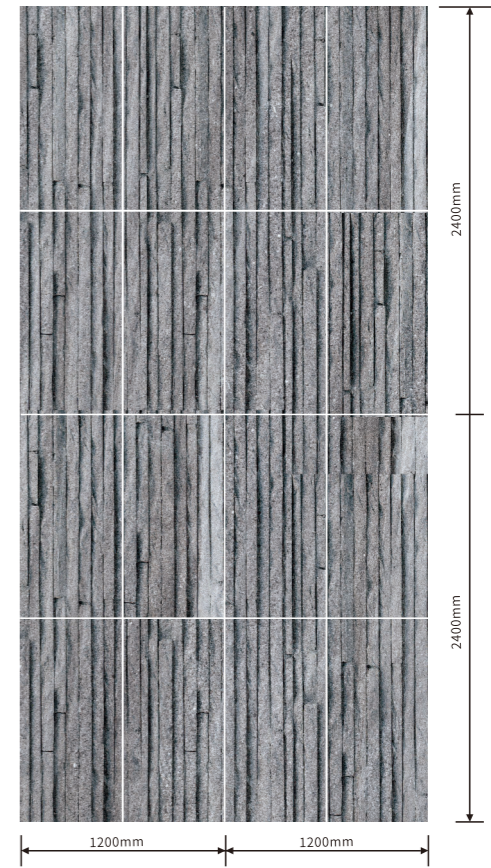

More color options

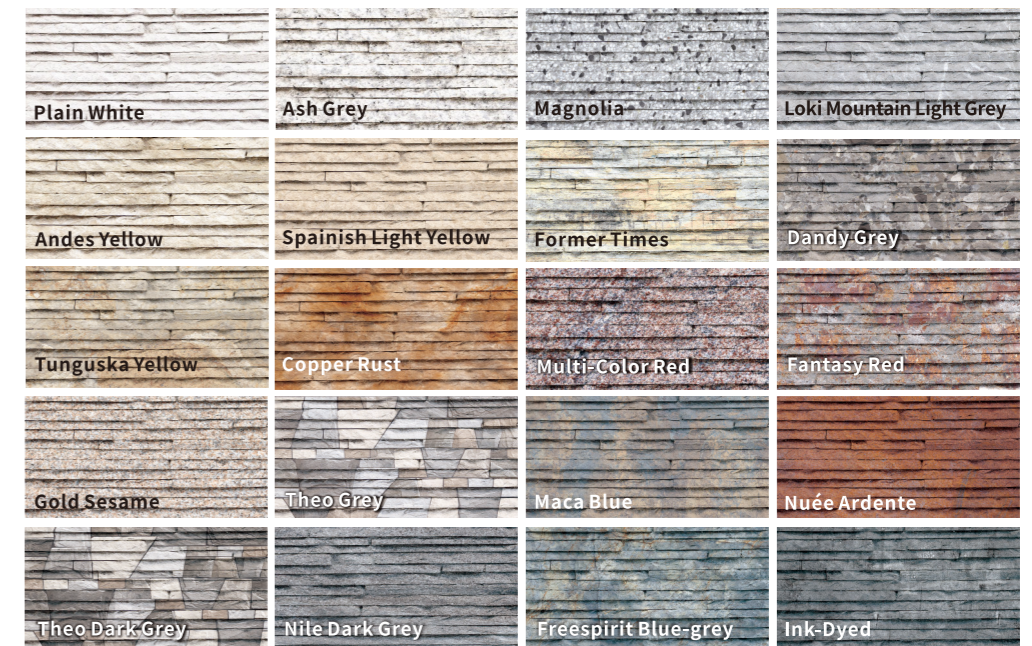

Specification and packaging

Generation	Standard Size (mm)	Thickness(mm)	Packaging(mm)	Pcs/box	Sqm/box
3.0	600 x 300	1-9 natural unevenness	620 x 320 x 90	8	1.44
	1200 x 600		1220 x 620 x 75	6	4.32

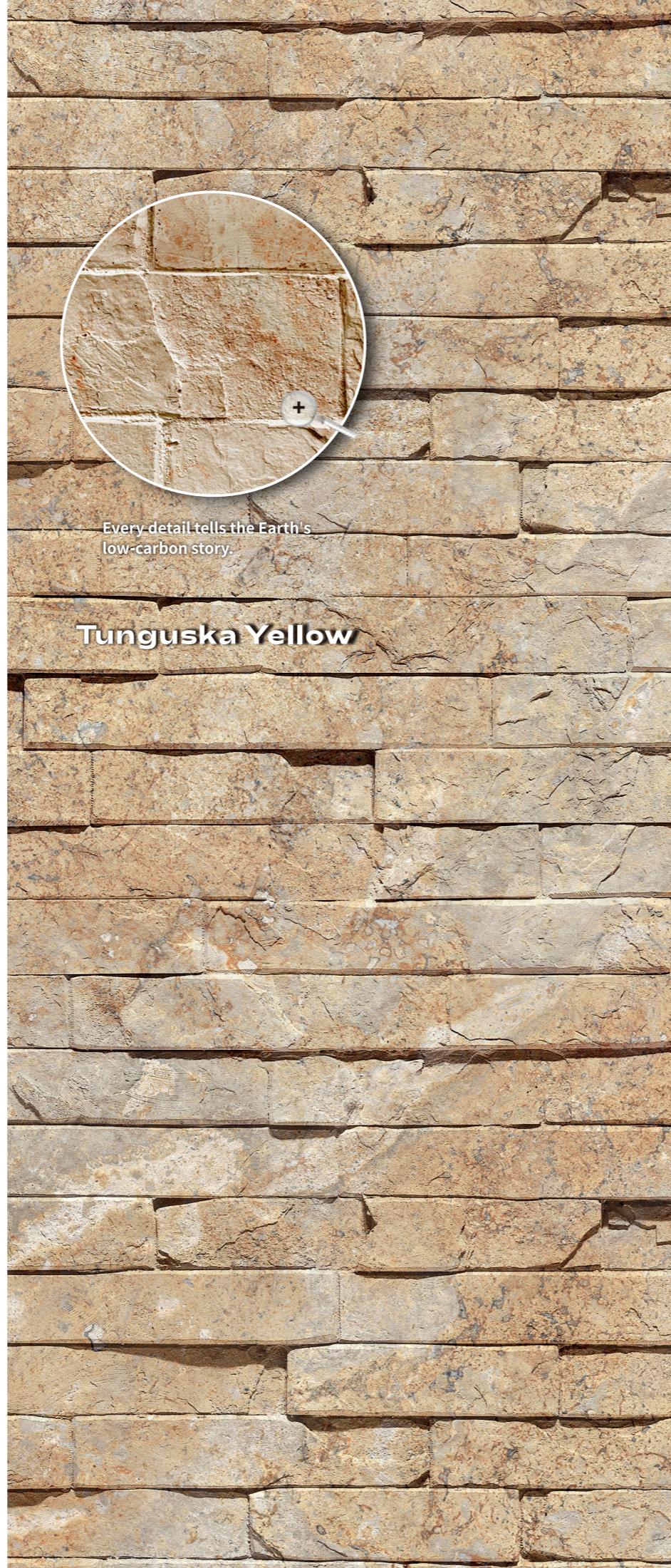

Every detail tells the Earth's low-carbon story.

Tunguska Yellow

When building materials heal the Earth, humankind will understand its wounds.

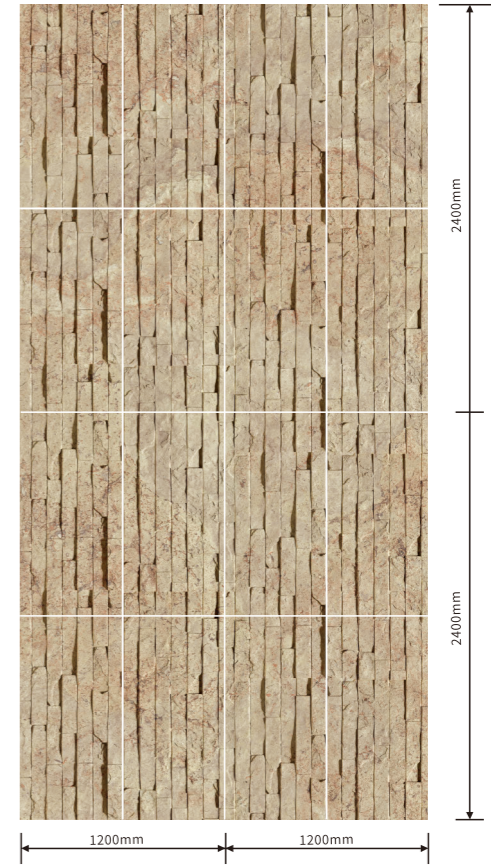

More color options



Specification and packaging

Generation	Standard Size (mm)	Thickness(mm)	Packaging(mm)	Pcs/box	Sqm/box
3.0	600 x 300	1-9 natural unevenness	620 x320x90	10	1.8
	1200 x 600		1220 x 620x75	8	5.76

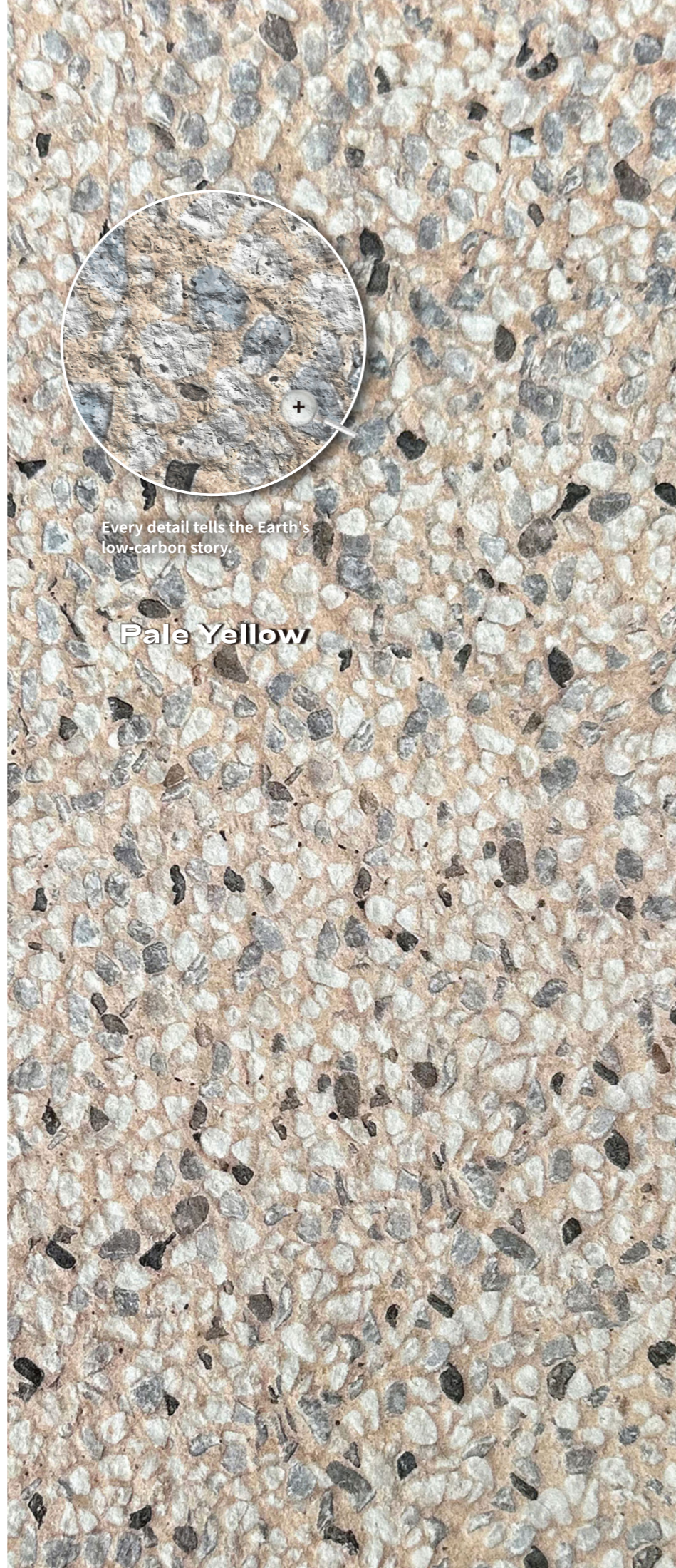
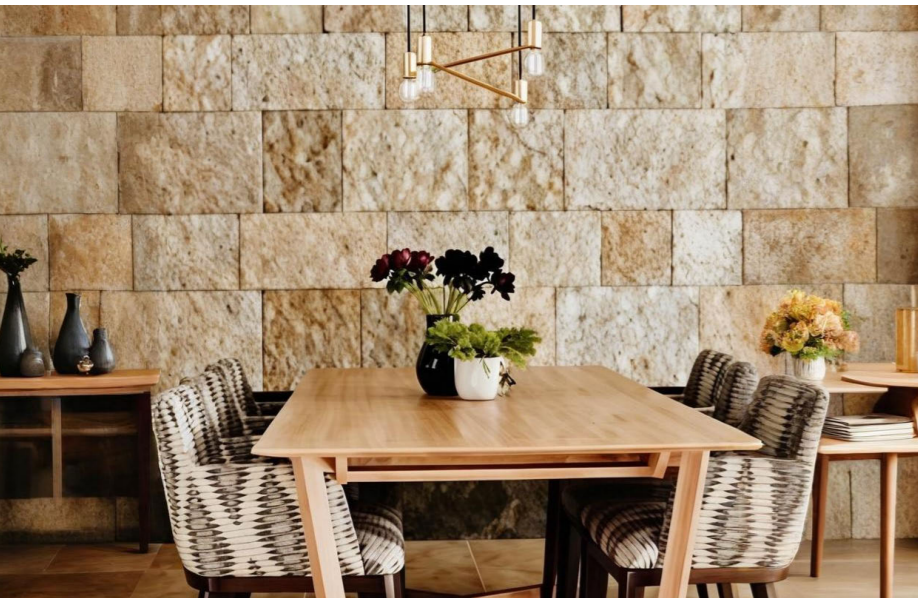

Every detail tells the Earth's low-carbon story.

Pale Yellow

Redefining building materials: Customizable textures
× Programmable patterns × Infinite colors.

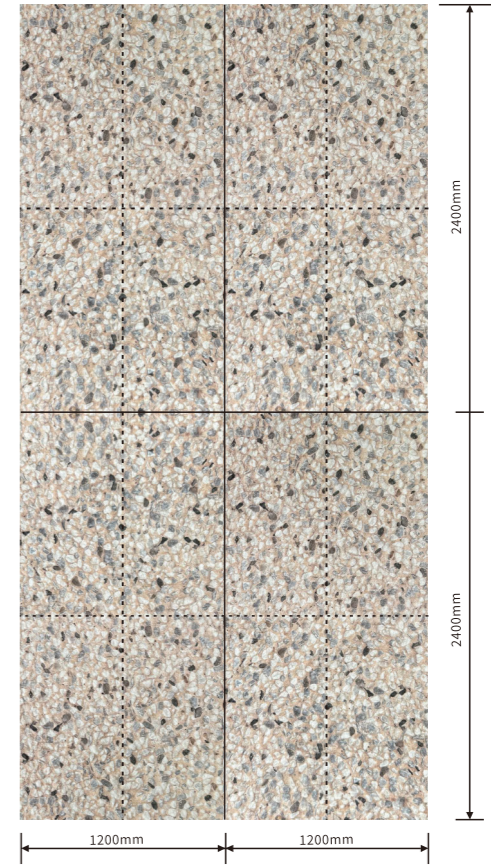

More color options



Specification and packaging

Generation	Standard Size (mm)	Thickness(mm)	Packaging(mm)	Pcs/box	Sqm/box
3.0	900 x 600	1-3.5	920 x 620 x 80	20	10.08
	1380 x 600		1400 x 620 x 65	18	14.904
	2760 x 1200		Sizes above 2400x1200 are packed with wooden case as per order quantity (subject to packaging fee)		
4.0	1200 x 600	1-4	1220 x 620	14	10.08

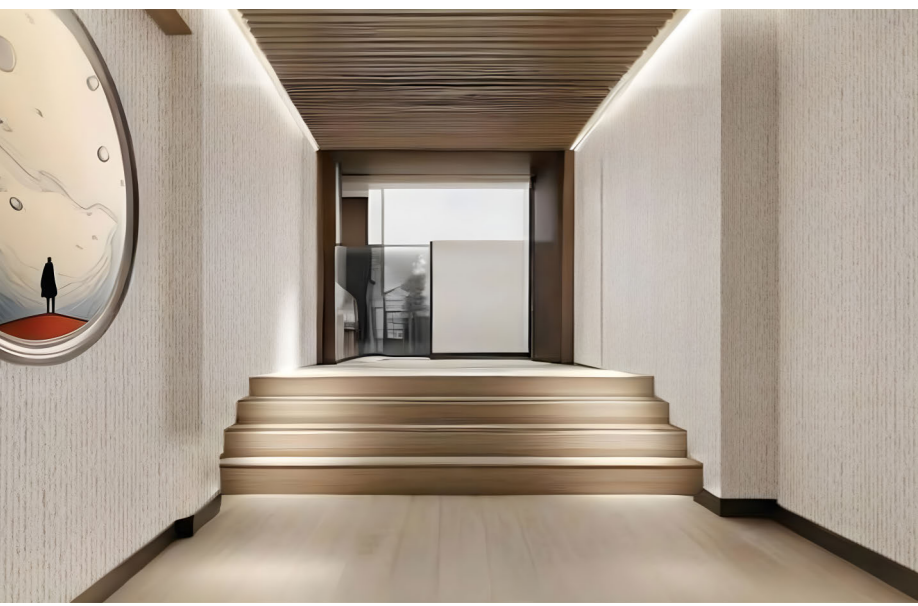

Endless materials, textures, and colors, shaping the future of architectural beauty.

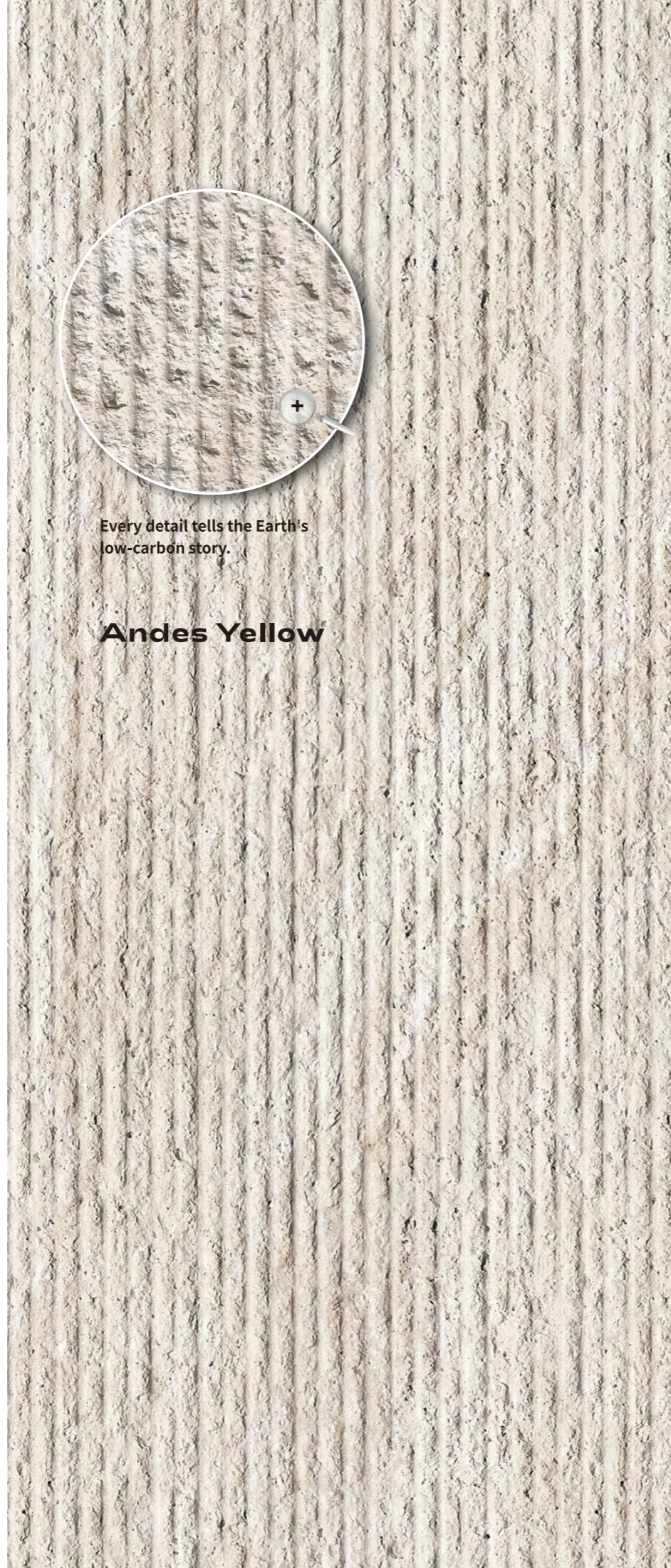

Every detail tells the Earth's low-carbon story.

Andes Yellow



More color options



Specification and packaging

Generation	Standard Size (mm)	Thickness(mm)	Packaging(mm)	Pcs/box	Sqm/box
3.0	1200 x 600	1-3.5	1220 x 620 x75	16	11.52
	2400 x 1200		2420 x 1230 x14	4	11.52



When facades become ecosystems,
concrete jungles nurture the forest.

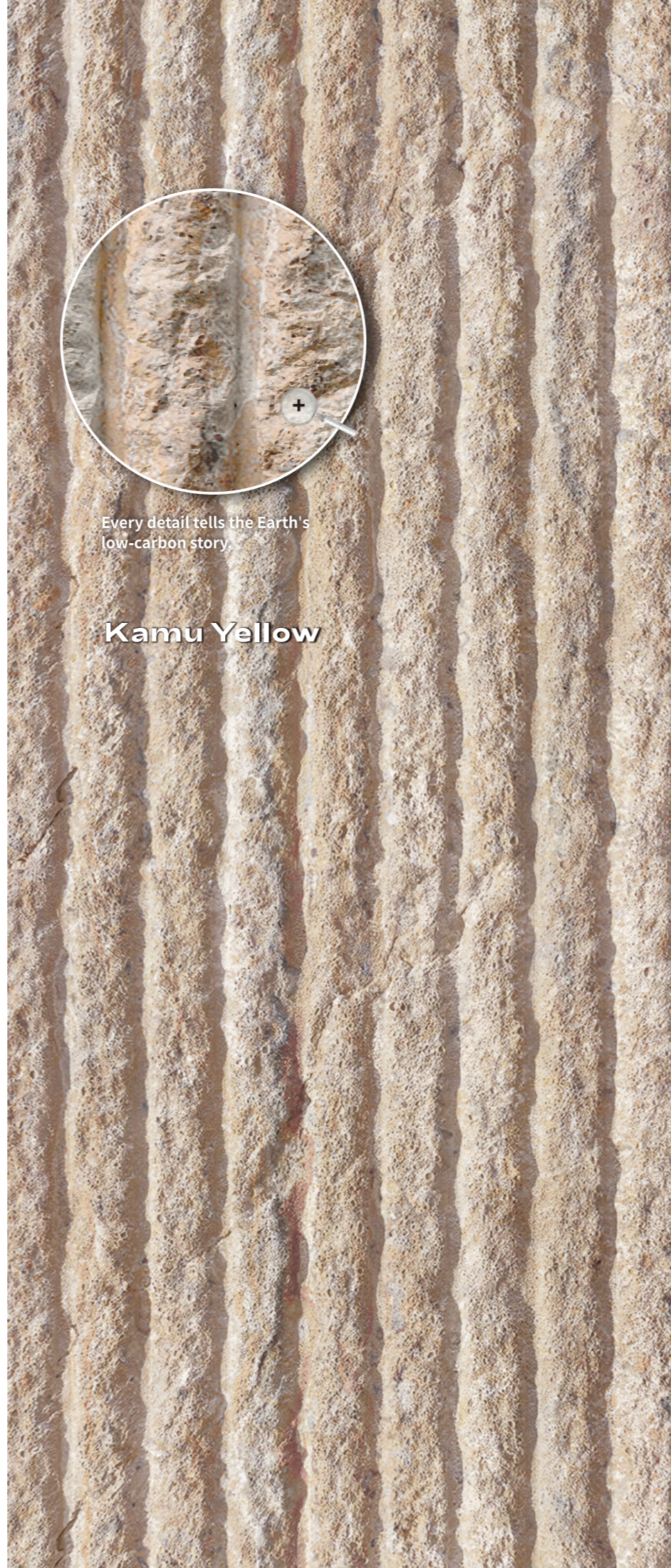

Every detail tells the Earth's
low-carbon story.

Kamu Yellow



More color options



Specification and packaging

Generation	Standard Size (mm)	Thickness(mm)	Packaging(mm)	Pcs/box	Sqm/box
3.0	1350x600	1-7 natural unevenness	1380 x 620 x 65	8	6.48
	2700x600				
	(2700-6000) x 1200				
4.0	1200x600	1-6.8 natural unevenness	1220 x 620 x 65	8	5.76

Sizes above 2400x1200 are packed with wooden case as per order quantity (subject to packaging fee)



Redefining building materials: Customizable textures
 × Programmable patterns × Infinite colors.

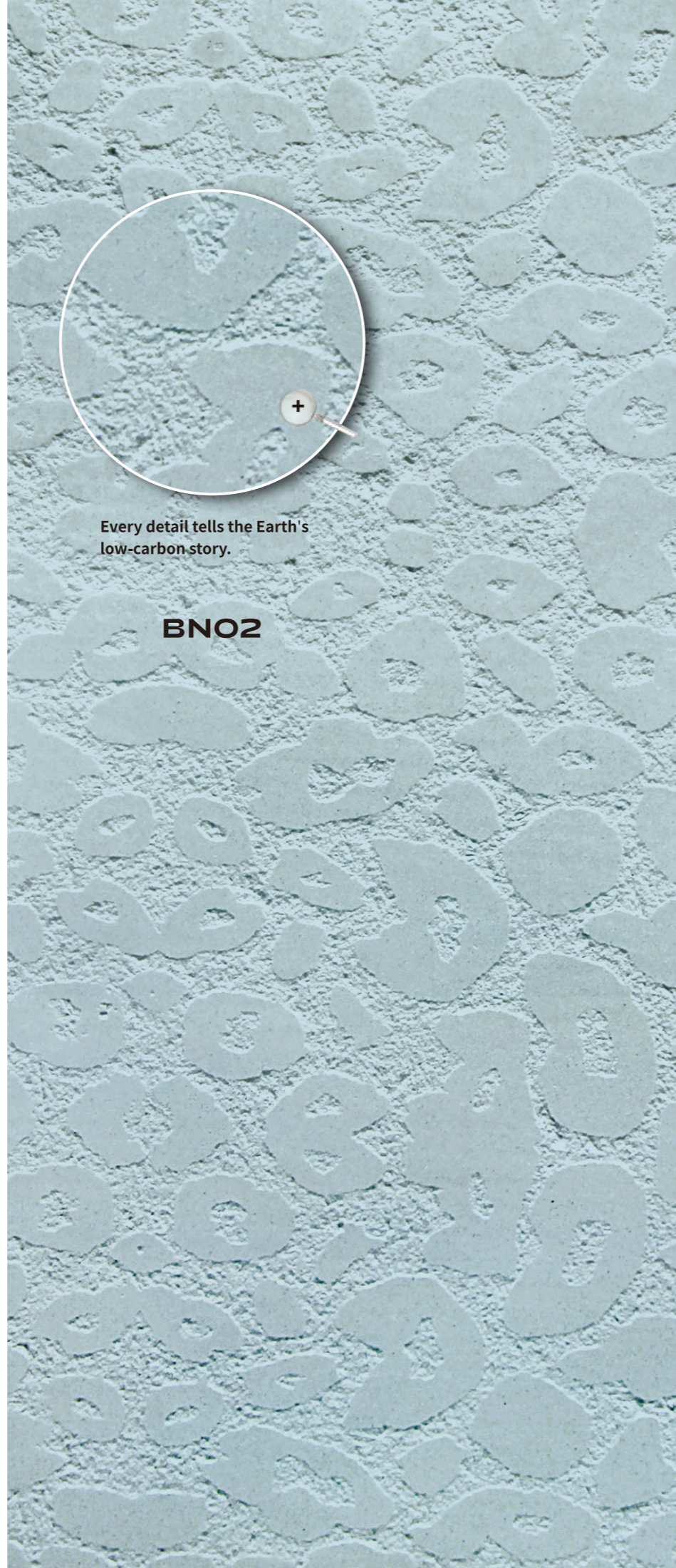

Every detail tells the Earth's low-carbon story.

BN02

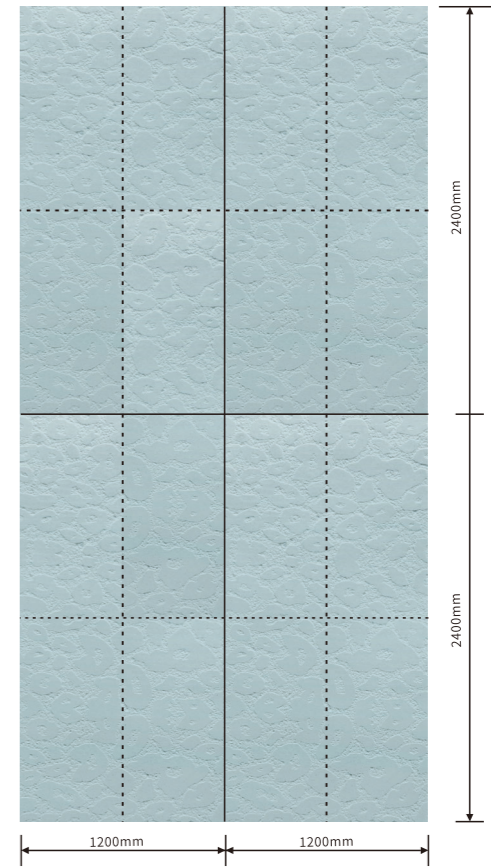

More color options



Specification and packaging

Generation	Standard Size (mm)	Thickness(mm)	Packaging(mm)	Pcs/box	Sqm/box
3.0	2600 x 1200	3.5(±1)			



Architects' Freedom Trio: Seamless Materials + Infinite Textures + Unlimited Color Palette

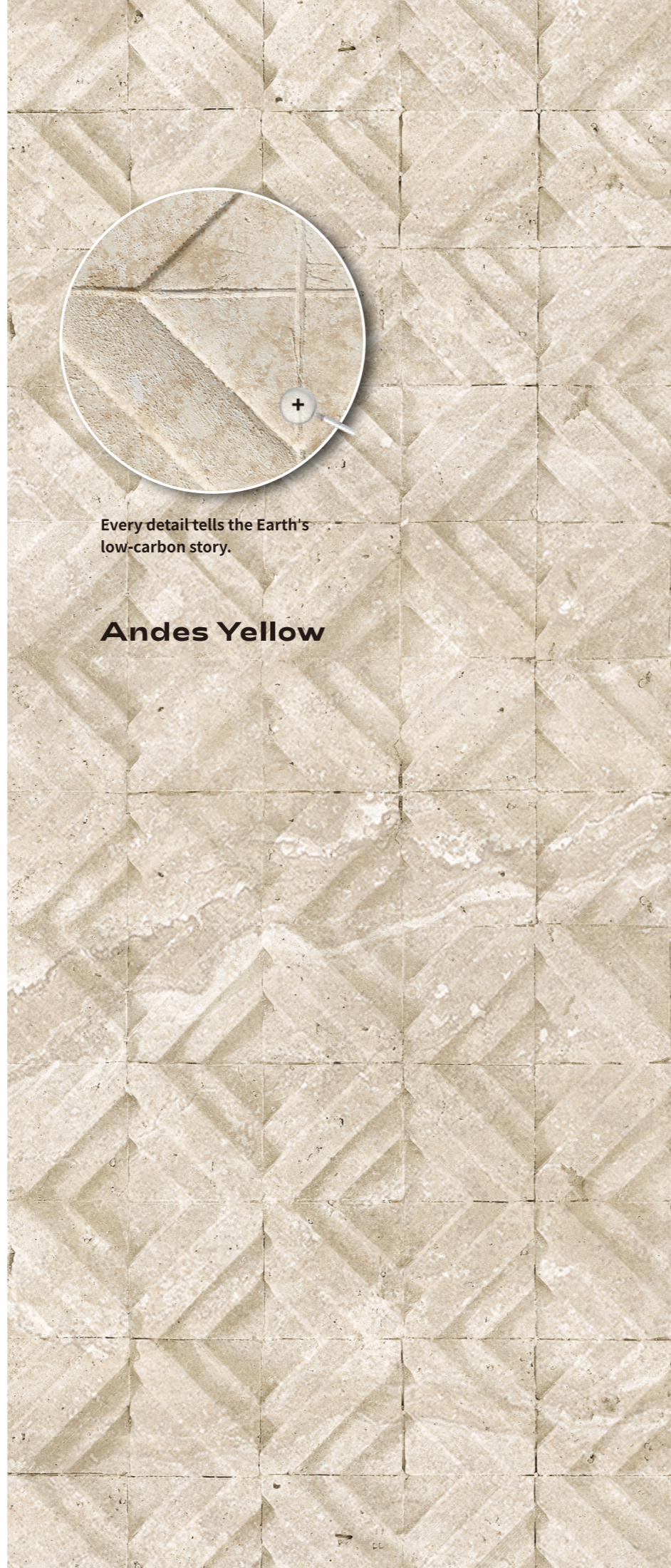

Every detail tells the Earth's low-carbon story.

Andes Yellow

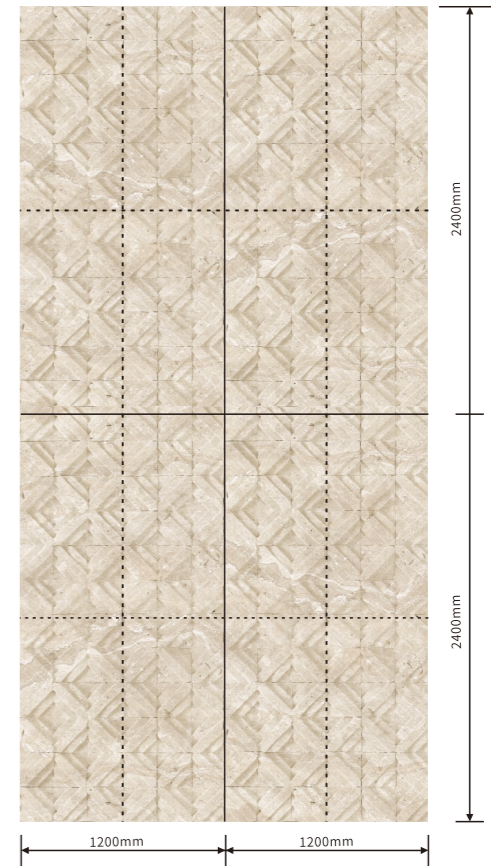

More color options



Specification and packaging

Generation	Standard Size (mm)	Thickness(mm)	Packaging(mm)	Pcs/box	Sqm/box
3.0	600 x 600	1-7.5	620 x 620x90	12	4.32
4.0	1200 x 600		1220 x 620x75	10	7.2



"Digital precision, restoring the physical world."

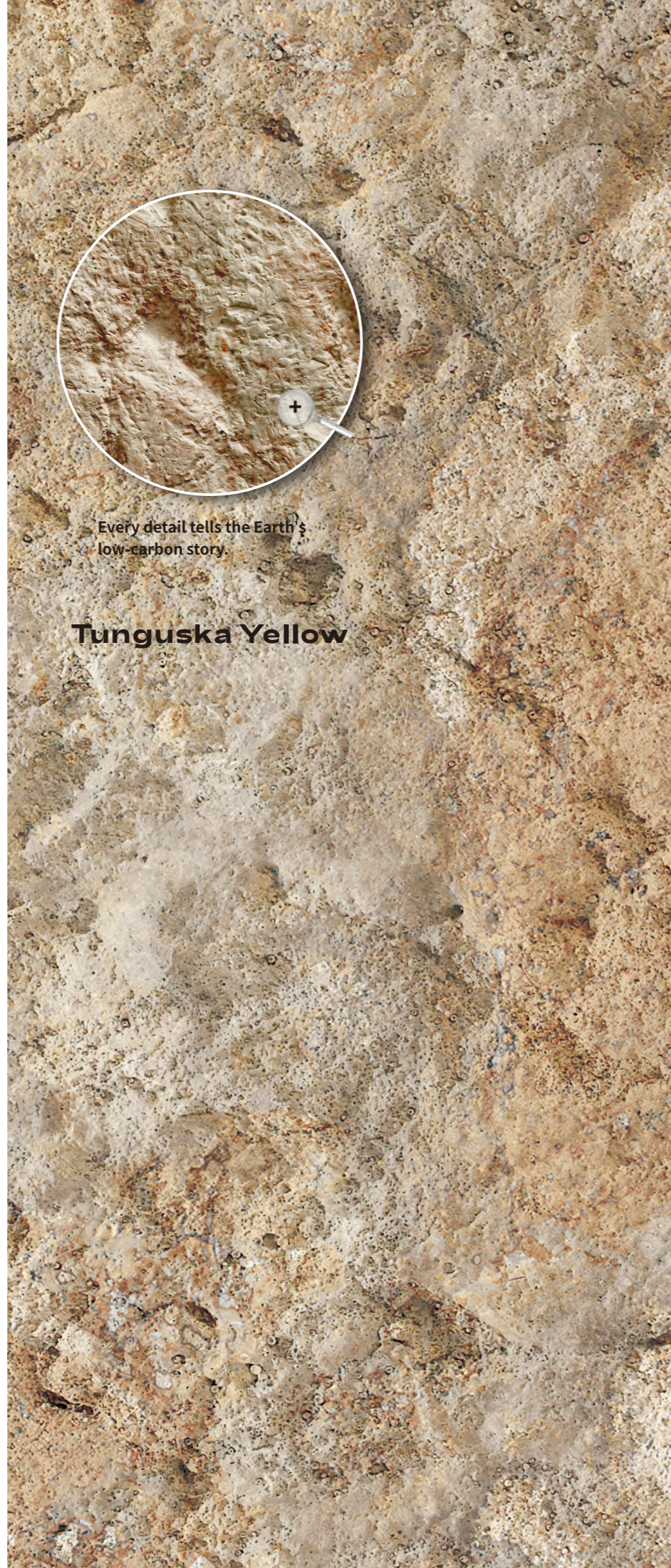

Every detail tells the Earth's low-carbon story.

Tunguska Yellow

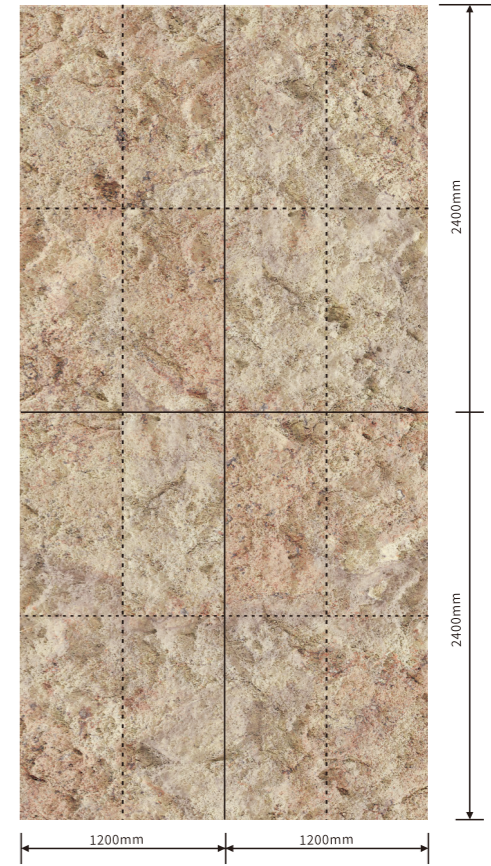

More color options



Specification and packaging

Generation	Standard Size (mm)	Thickness(mm)	Packaging(mm)	Pcs/box	Sqm/box
3.0	1200 x 600	1-10 natural unevenness	1220x620x75	6	4.32
	1200 x 1200				
	2400 x 1200				

Texture options



Primary colors: Plain White

Example of mixed effect - partial view

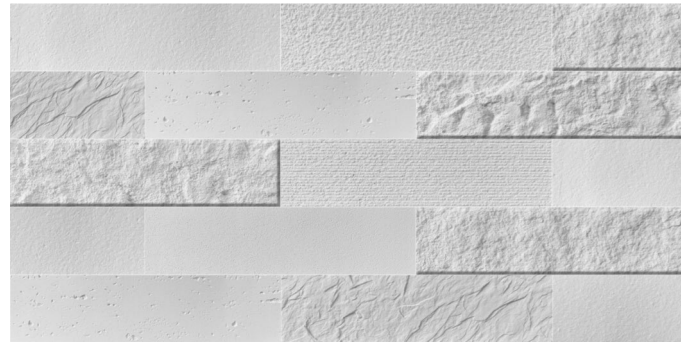

Texture: Marble, Rough Surface, Mount Celestial, Travertine, Rockface Stone, Stone Ridged, Bush Hammered, Sandstone, Devine Mushroom Stone.

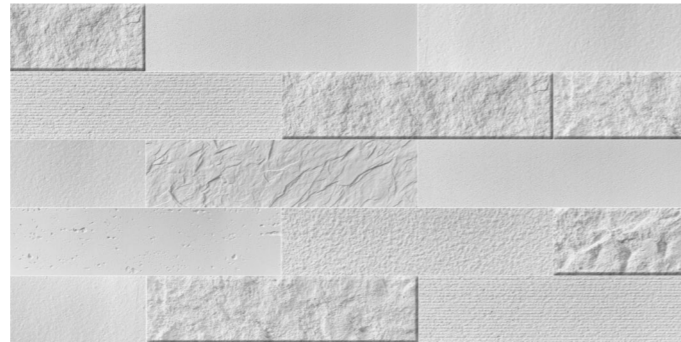

Texture: Marble, Rough Surface, Mount Celestial, Travertine, Rockface Stone, Stone Ridged, Bush Hammered, Sandstone, Devine Mushroom Stone.

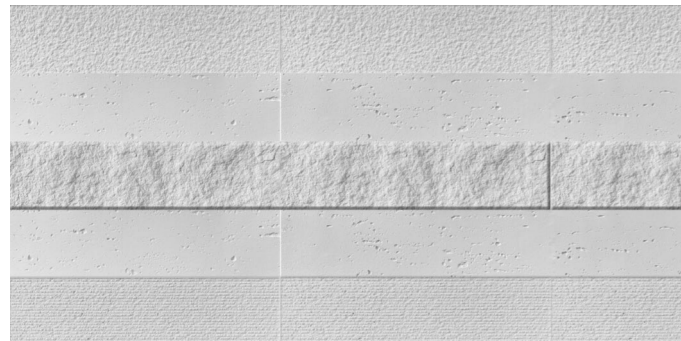

Texture: Rough Surface, Stone Ridged, Bush Hammered, Travertine

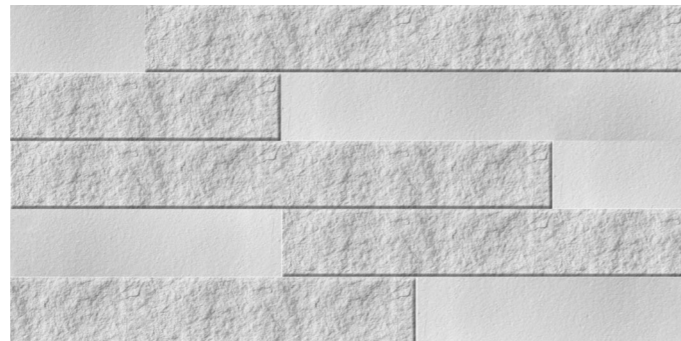

Texture: Marble, Rough Surface

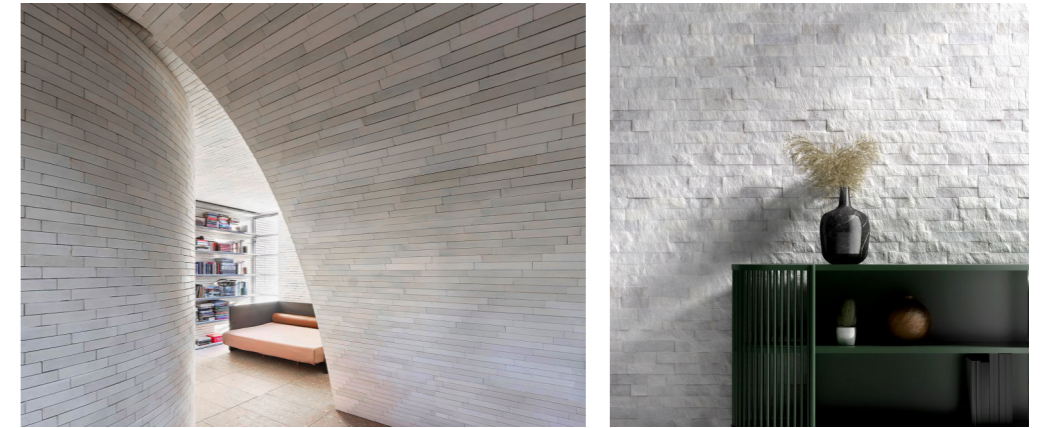

From limits to infinite possibilities.

Specification and packaging

Texture	Generation	Standard Size (mm)	Thickness(mm)	Packaging(mm)	Pcs/box	Sqm/box
Rockface Stone	3.0	480x120	1-10 natural unevenness			
		960x120				
Travertine	3.0	480x120	3.3(±1)			
		960x120				
Stone Ridged	3.0	480x120	1-3.5			
		960x120				
Devine Mushroom Stone	3.0	480x120	1-8 natural unevenness			
		960x 120				
Bush Hammered	3.0	480x120	1-3.5			
		960x120				
Rough Surface	3.0	480x120	1-6 natural unevenness			
		960x120				
Marble	3.0	480x120	2.8(±1)			
		960x120				
Sandstone	3.0	480x120	2.8(±1)			
		960x120				
Mount Celestial	3.0	480x120	1-4			
		960x120				

Energy Efficiency Comparison:

Power Efficiency: 60% HIGHER than glass BIPV with 60% transmittance (CQC/TUV certification)
Carbon Emissions: 54.6% lower than glass BIPV (BV certification)



eSolarFacade technical specifications

ELECTRICAL SPECIFICATIONS		I-V CURVES	
Test Conditions	STC		
Maximum Power (Pmax)	59.23 ~ 166.62 W		
Maximum Power Voltage (Vpmax)	20.70 ~ 29.22 V		
Maximum Power Current (Ipmax)	2.86 ~ 5.70 A		
Open Circuit Voltage (Voc)	24.18 ~ 35.52 V		
Short Circuit Current (Isc)	3.15 ~ 6.17 A		
Module Efficiency	9.12% ~ 17.63%		
Maximum System Voltage (VDC)	1000 V (TUV/CE/CB/CQC/UKCA)		
Series Fuse Rating	25 A		
Power & Other Electrical Specification Tolerance	5%		

STC: Standard Test Conditions 1000 W/m² - AM 1.5 - Temperature 25°C

MECHANICAL PROPERTIES	
Module Weight	15.28kg/m ³ (variable for different texture)
Dimensions (L x W x T)	1140x570x30mm, 1200x600x30mm, 1254x751x30mm, 1260x746x30mm
Maximum Surface Load (Wind / Snow)	2400 Pa rear & front
Hail Impact Resistance	ø 25mm @ 23.0 m/s
Fire Rating	A
Glass	No
Back support	Aluminium honeycomb composite panel
Cables & Connectors	300mm, 1000mm, 1200mm, 4mm ²
Front layer	econiclays Coverings (High durability, UV resistant)
Backsheet	econiclays Coverings (High durability, UV resistant)
Bypass Diodes	2 diodes
Junction Box	Ip68 rated, TUV certified

TEMPERATURE RATINGS		WARRANTY	
Temperature Coefficient Isc	0.036% /°C	Product Warranty: 25 years Performance Warranty: fi ≥ 98% end of 1st year fi ≥ 90% end of 12th year fi ≥ 80% end of 25th year	
Temperature Coefficient Voc	-0.25% /°C		
Temperature Coefficient Pmax	-0.30% /°C		
Nominal Module Operating Temperature	42 ± 3°C		
Operating Temperature	-40°C ~ +85°C		

Certifications



eSolarFacade

Partner with the Sun to Power Buildings on

Winner of the 123rd Paris International Invention Gold Award

Winner of the 76th International Exhibition of Inventions Nuremberg

Partner with the Sun to Power Buildings On

Stone, Reinvented with Photosynthesis
— A Sustainable Choice for 237 Iconic Landmarks Worldwide

PHOMI eSolarFacade
(econiclay Building Integrated Photovoltaics)



Glass BIPV
(Building Integrated Photovoltaics)



Compared to glass BIPV

Efficiency: eSolarFacade vs. glass BIPV (60% light transmittance) – 60% higher power output (CQC/TUV certification).

Carbon Emissions: Reduced by 54.6% (BV certification).

Application Scenarios:

Ideal for non-glass facade decorations for stations, airports, sports venues, road sides, bridge piers, and fences, offering both decoration and green energy solutions.



eSolarFacade advantages

Unlimited Material Expressiveness:

Achieves the same effect as natural materials like stone, wood, and brick, seamlessly blending with the facade.

Breaking Traditional Photovoltaic Limits:

Over 95% of buildings use non-glass curtain walls, while regular BIPV is limited to glass facades and windows. eSolarFacade breaks this barrier, enabling flexible use in various architectural styles, expanding photovoltaic technology in the building sector.

Higher Efficiency, Lower Carbon Emissions:

eSolarFacade offers over 60% higher power conversion efficiency than glass BIPV with 60% transmittance, reducing carbon emissions by over 54.6%.

More Customization Options:

Beyond power generation, eSolarFacade can be tailored for advertising, insulation, negative ion release, and more, enhancing building performance and comfort.



"When photovoltaics become the most versatile building material, its texture, finish, and color can all be customized."

"Green Calculations for Government Projects"

For a 100,000 m² public building, achieve a net carbon reduction of 8,452 tons annually (equivalent to planting 470,000 fir trees over 30 years).

Double Carbon Reduction vs. Glass BIPV

- ✓ Improved Power Generation: 67% efficiency increase → 3.4 million kWh of clean energy → 2,132 tons CO₂ saved
- ✓ Lower Production Emissions: 50% reduction in carbon intensity per watt → 1,120 tons CO₂ saved

Revolutionizing Building Materials vs. Natural Stone

- ✓ Material Innovation: 66.7% lower carbon footprint per unit area → 5,200 tons CO₂ saved across the building

Calculation of Carbon Reduction for 100,000 m² Building:

Carbon reduction path	Formula	Results
More carbon reduction through power generation	$100,000\text{m}^2 \times 4\% \times 1,000\text{kWh}/\text{m}^2 \times 0.627\text{kg}/\text{kWh}$	→2,132 tons
Less carbon emission in production	$(0.52-0.26)\text{kg}/\text{Wp} \times 10,000\text{kWp}$	→1,120 tons
Carbon reduction through material substitution	$(78-26)\text{kg}/\text{m}^2 \times 100,000\text{m}^2$	→5,200 tons
Total net carbon reduction	$2,132+1,120+5,200$	8,452 tons



Photovoltaic stone facades, energizing curtain walls—every inch of building texture becomes a reservoir of light energy.

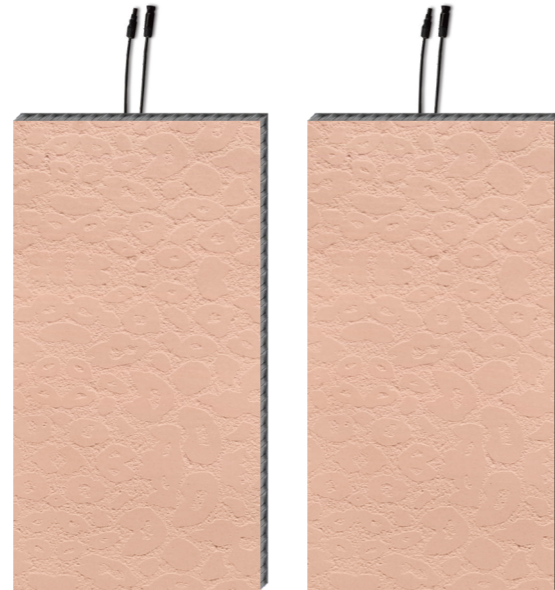

eSolarFacade Butterfly Stone ONO2
1140mmX570mm 50W/m² -120W/m²



Stone Aesthetics, Redefined

60% more efficient than transparent glass BIPV, with no compromise on the pure stone look.

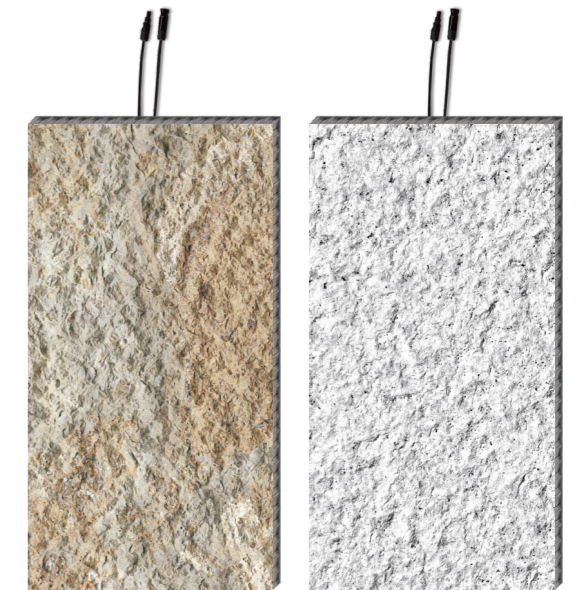

eSolarFacade Bush Hammered Tunguska Yellow/Ash Grey
1140mmX570mm 50W/m² -120W/m²

The Silent Money Printer for Villa Facades

A 200m² facade generates 2,400 kWh annually—60% more efficient than 60% transparent glass BIPV, covering over 70% of household energy consumption.

Building Facade Asset Formula

Choose PHOMI's eSolarFacade solution over glass BIPV — 60% more efficient per sqm, earning an extra 12.5 million USD in 25 years for every 100,000 m².

[10,000 m² Curtain Wall = Vertical Power Plant + Carbon Sink Forest]

Carbon Reduction Efficiency

→ 58% lower lifecycle carbon footprint compared to Glass BIPV (0.26 kgCO₂e/Wp vs. industry average of 0.62 kgCO₂e/Wp)

→ 63% reduction in carbon emissions compared to Stone Curtain Walls (Stone Curtain Wall: 74 kgCO₂e/m² vs. e-solarfacade: 26 kgCO₂e/m²)

Economic Value

Energy Generation: 1.8 million kWh annually (based on 1200 hours of equivalent generation) ~ Electricity cost savings of 144,000 USD (0.08 USD/kWh)

Carbon Assets: Annual CO₂e reduction of 1,440 tons (coal replacement) ~ Carbon revenue of 11,520 USD (2025 carbon price: 8 USD/ton)

Ecological Contribution

Equivalent to the carbon sequestration of 144,000 trees per year = Offsetting the annual exhaust emissions of 1,000 fuel-powered vehicles.



Photovoltaic stone facades, energizing curtain walls—every inch of building texture becomes a source of light.

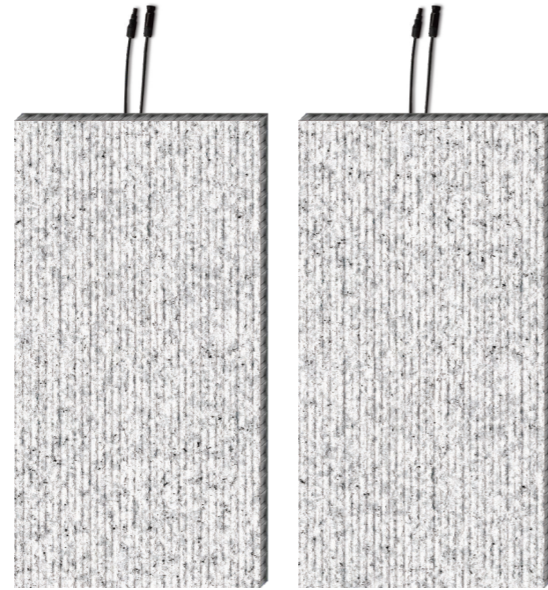

eSolarFacade Stone Ridged Ash Grey
2300mmX570mm (customized size)
50W/m² -120W /m²



Photovoltaic stone facades, energizing curtain walls—every inch of building texture becomes a reservoir of light energy.



eSolarFacade Bush Hammered Pale Yellow
1140mmX570mm 50W/m² -120W /m²

PHOMI eSolarFacade | Carbon Neutral Facade System Solution

6,000m² Curtain Wall with Dual-Effect Value

- Annual Power Generation: 600,000 kWh (0.6 MW capacity × 1,000 hours)
- Lifecycle Carbon Footprint: 0.26 kgCO₂e/Wp (BV certification)

Carbon Reduction Comparison

- Glass BIPV: eSolarFacade is 58% lower carbon footprint (vs. 0.62 kgCO₂e/Wp for glass BIPV)
- Stone Curtain Wall: eSolarFacade is 65% lower carbon emissions (vs. 74 CO₂e/m² for stone)

Economic Value

- Electricity Bill Annual Savings: 48,000 USD (0.08 USD/kWh electricity rate)
- Carbon Trading Revenue: 6,912 USD (8 USD/ton carbon price × 864 tons)

Ecological Contribution

- Carbon Sequestration: Equivalent to 48,000 trees
- Carbon Offset: Equivalent to 340 vehicles' annual emissions.

PHOMI eSolarFacade | Carbon Neutral Solution for Small & Micro Buildings

[1,000m² Curtain Wall with Dual-Effect Value]

- Annual Power Generation: 120,000 kWh (0.10 MW capacity × 1,200 hours of equivalent generation)
- Lifecycle Carbon Footprint: 0.26 kg CO₂e/Wp (BV Certification)

Full-Cycle Economic Benefits

- Annual Electricity Savings: 9,600 USD (at industrial/commercial rate of 0.08 USD/kWh)
- Carbon Trading Revenue: 115.2 USD (2025 carbon price: 8 USD/ton × 14.4 tons)

Ecological Impact

- Carbon Sequestration Equivalent: 9,600 trees' annual absorption.
- Equivalent to 87 National VI Fuel Vehicles' Annual Emissions.

Note: Data based on an installation density of 150 Wp/m² and a coal power emission factor of 0.8 kg CO₂e/kWh.

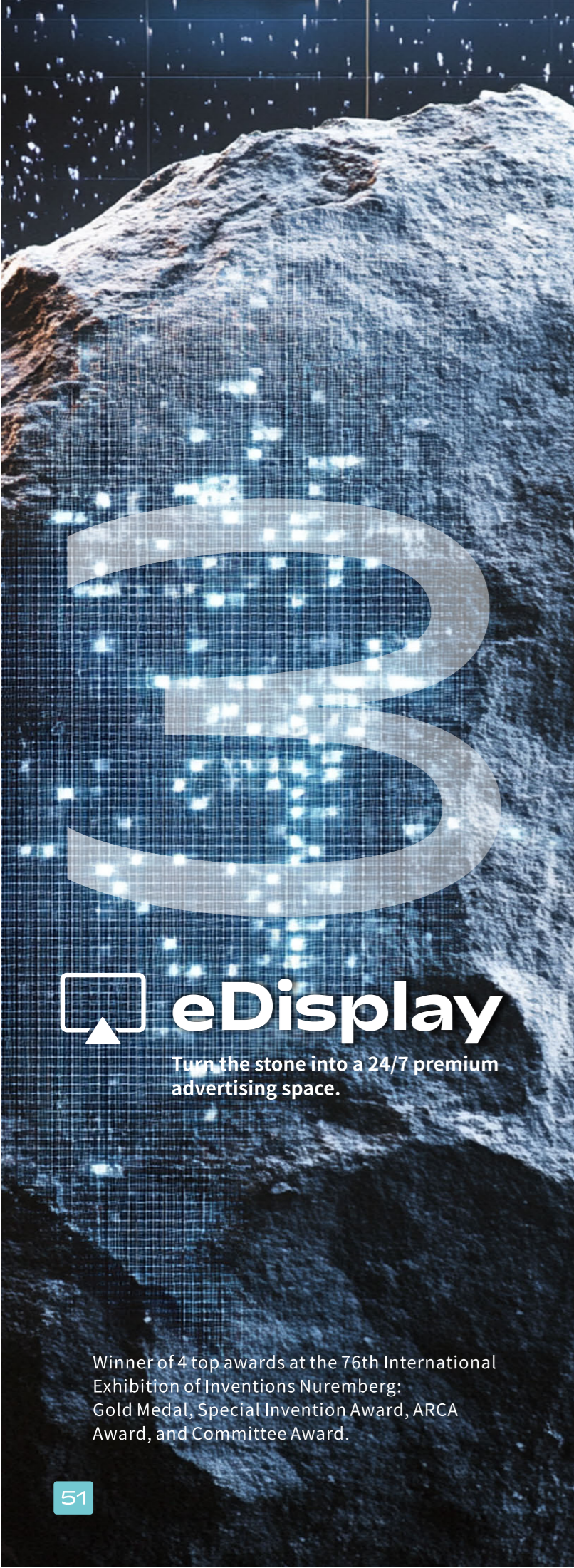

eDisplay

Turn the stone into a 24/7 premium advertising space.

Winner of 4 top awards at the 76th International Exhibition of Inventions Nuremberg: Gold Medal, Special Invention Award, ARCA Award, and Committee Award.

Technical Principles

Phomi invented a covering material with one-way light guiding capability for display purpose - eDisplay. The core of this technology lies in precise manipulation of the microstructure of the covering material to achieve efficient unidirectional transmission of light. Through state-of-the-art technology, a specific optical channel network is constructed at the microscopic level, allowing the light generated by optoelectronic materials to propagate along a predetermined path and ultimately exit through specific areas of the covering material, forming a clear and coherent video signal output.

In addition to technological innovation, eDisplay also incorporates aesthetic design to simulate the natural texture of stone, the warm texture of wood or the rustic look of terracotta bricks through surface treatment, which is virtually unaffected by light conduction, ensuring that the eDisplay system can still present a pleasing visual effect while displaying video content. Moreover, eDisplay has a lower carbon footprint during its life cycle, which meets the requirements of green and sustainable development.

eDisplay is expected to become the mainstream choice in the field of display in the future, widely used in architectural decoration, information display and other fields, opening a new chapter in display technology.

Core Values

1. Architectural Revolution

a. Seamless Material-Display Fusion: Instantly convert stone, wood, or brick facades into 4K displays—disappearing when powered off. Interior surfaces such as walls, ceilings, and floors become interactive displays.

b. Invisible design: integrated display units with the building material, zero-exposure design, replacing traditional external LED screens.

2. Solar-Storage-Display System

Paired with eSolarFacade curtain walls, this system cuts external power consumption by 80%, offering a sustainable “display-generation-storage” solution.

3. Smart Aesthetic Adaptation

AI-driven adjustments automatically optimize brightness and texture for seamless integration.

4. Unlocking Commercial Value

Outdoor: Facades transform into 2,000-nit digital billboards, boosting ad revenue and space value.

Indoor: Retail walls instantly become immersive product displays, increasing customer stop time by 40%.



eDisplay Specifications

Parameter	Outdoor (night use only)	Outdoor (day and night use)	Indoor
Panel size	640x160/640x320/960x320/ 1280x640/1600x480/1920x480 mm	640x320/1280x320/ 1280x640/1920x320 mm	640x160/640x320/960x320/ 1280x640/1600x480/1920x480 mm
Resolution	P4	P6.67	P2.5
Pixel density	62500 dot/m ²	22500 dots/m ²	160000 dot/m ²
White balance brightness	1000-2000 cd/m ²	4000-5000 cd/m ²	≥800 cd/m ² Adjustable
Color temp.	3000-15000K	6500-8000K	3000-15000K
Power Consumption	Peak ≤ 1200W/m ² Avg ≤ 750W/m ²	Peak 520W/m ² Avg 173W/m ²	Peak ≤ 861W/m ² Avg ~287W/m ²
Refreshing freq.	50-60 Hz	60 Hz	50-60 Hz
Frame rate	≥1920 Hz	3840 Hz	≤3840 Hz
Working temp.	-20 ~ 50°C		
Control system adaptable	Colorlight	CHIPSHOW / Windows	Colorlight
Maintenance Method	Back - access Maintenance		
Remark	One finished panel includes cable, power supply, receiving card.		

Certifications



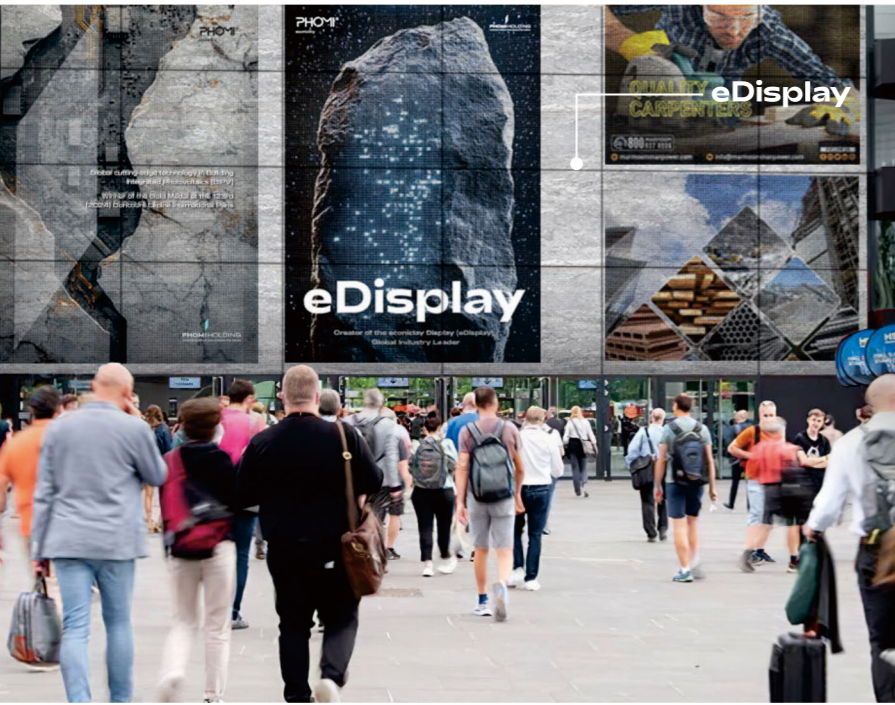

「Turn your stone facade into a 2000nit digital billboard, boosting revenue and property value.」



「Transform concrete into a live show in 0.3 seconds」

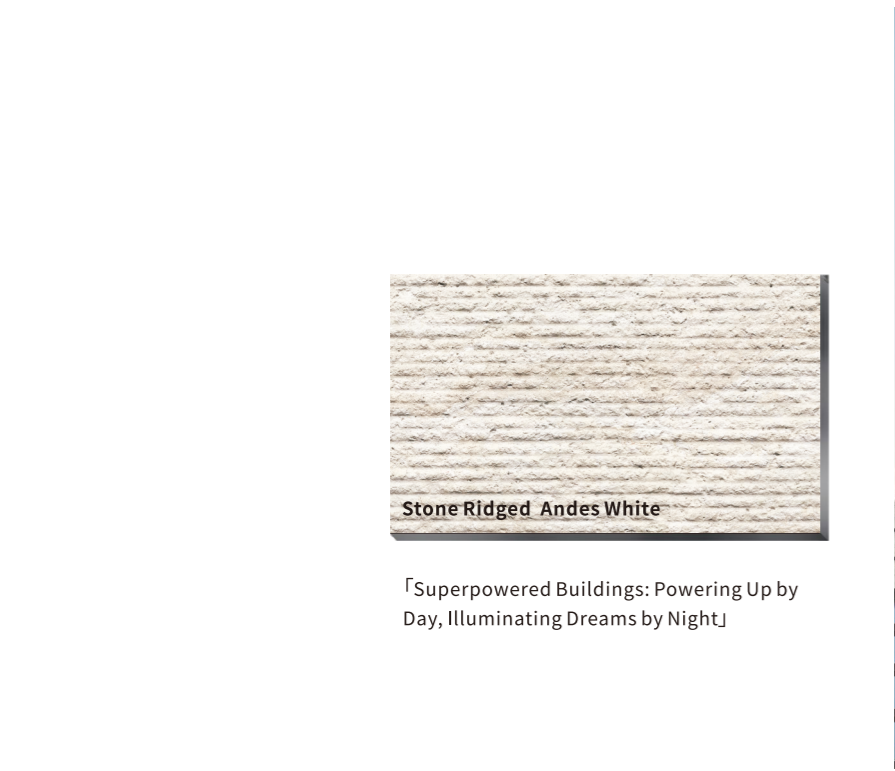
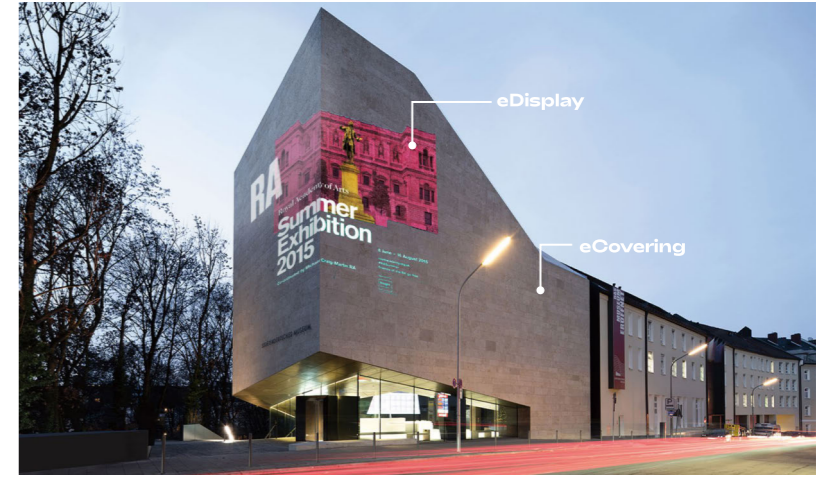

「Superpowered Buildings: Powering Up by Day, Illuminating Dreams by Night」

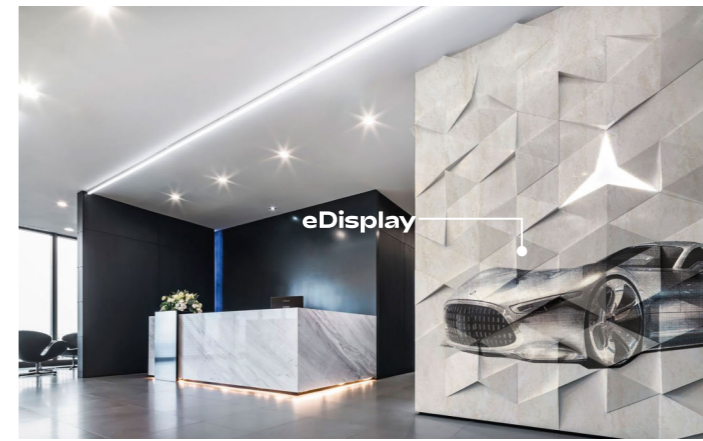
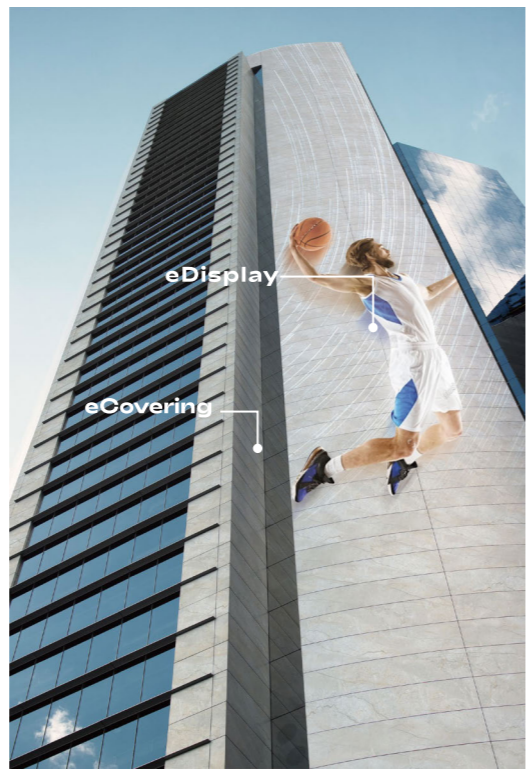

「Each stone is an 8K canvas」



「Silent as stone, dynamic as smart vision—let your space tell your brand's story」



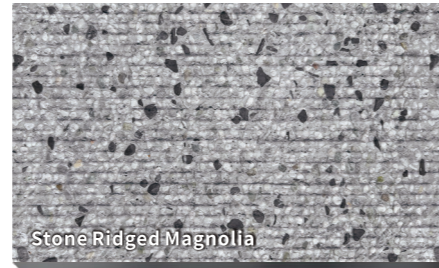

「Instantly Activated, Discreetly Hidden – Travertine Wall Becomes a Smart Info Screen」



「Stone walls turn into destination screen: The Eiffel Tower emerges, with lavender star rain falling from above」

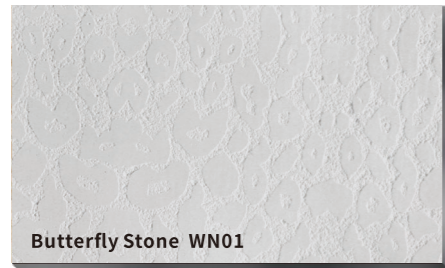

「Transform your restaurant wall into an 8K movie experience, with a starry sky above」



「With a simple tap, the wall comes alive, showcasing the Earth's evolution as a meteor shower」



「Stone walls in commercial spaces become immersive product displays, boosting customer stop time by 40%」

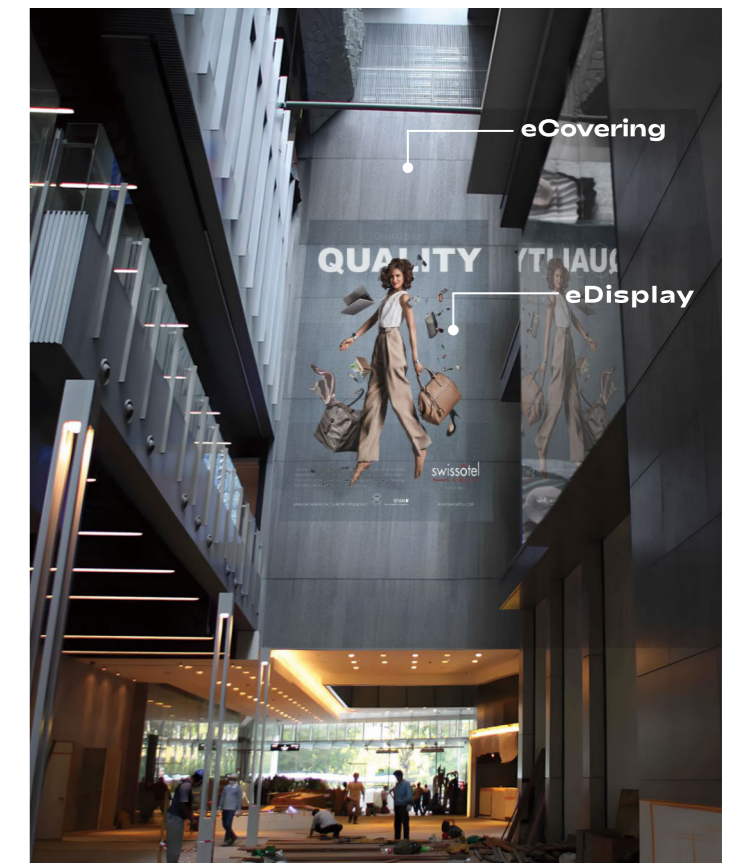

"When photovoltaics become the most versatile building material, its texture, finish, and color can all be customized."

Stone Ridged



Bush Hammered

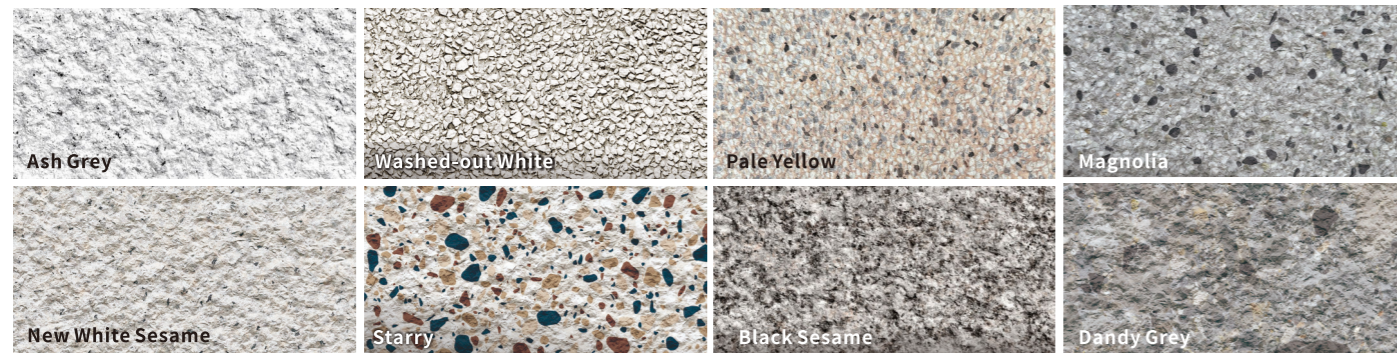

More color & specification options

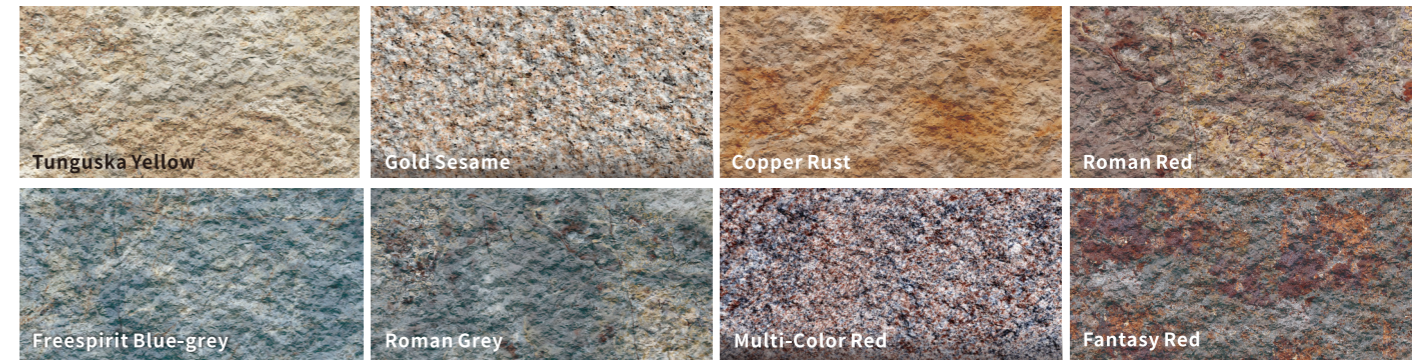

Butterfly Stone



Standard sizes

eDisplay:		eSolarFacade:
1920X320mm(exterior)	1004X754mm(exterior)	1140x570 mm
1280X640mm(exterior)	960X320mm(exterior)	
1280X320mm(exterior)	960X160mm(exterior)	
1280X480mm(exterior)	640X320mm(exterior & interior)	



Negative Ion Series

Integrated with nano-level negative ion technology, redefining architecture with a perfect fusion of health and aesthetics.

Each square meter of PHOMI stone rebuilds the harmony between architecture and nature.



Harnessing nano-scale negative ion technology to blend health with aesthetics in architecture.



Negative Ion Series

Each square meter of PHOMI stone rebuilds the harmony between architecture and nature.



Urban Ecological Breathing Revolution

When a city's architecture and landscaping fully adopt PHOMI eCoverings (based on 300 million m²):

1. Carbon Reduction

- ▶ Total Carbon Emission: 306 million kg CO₂
- ▶ Reduction vs. Traditional Stone: 21.89 million tons CO₂ (7.2% of Shenzhen's annual carbon emissions)
- ▶ Reduction vs. Tiles: 6.52 million tons CO₂ (equivalent to shutting down 2.2 large coal-fired power plants)

2. Urban Lung Capacity

- ▶ Releases 1.49 × 10¹⁵ negative ions per second
- ≈ The purification capacity of 46,000 hectares of Wutong Mountain Forest Park
- ≈ Provides 18 medical-grade air purifiers per citizen

3. Sustainability Impact

- Creates 2.8 times Shenzhen's natural carbon sink reserve for the Greater Bay Area
- Reduces smog days by 76% (based on Shenzhen's annual PM2.5 average)
- Cleans capacity equivalent to one-third of the Pearl River's annual runoff

Note: Conversion Basis

- 1) Based on Shenzhen's estimated annual carbon emissions of 300 million tons (2025 data)
- 2) Wutong Mountain National Forest Park area: 1,151 hectares, with a negative ion concentration of 2,800 ions/cm³
- 3) 1 kg negative ions ≈ cleans 10m³ of air pollutants



Carbon Neutral Equation for Lobby Spaces

[When a 1000m² office lobby adopts PHOMI eCoverings]

- ▶ **Carbon Reduction:** Cuts 72.98 tons of CO₂, equal to 17,000 barrels of unburned oil
- ▶ **Air Purification:** Releases 4.97 × 10¹¹ negative ions per second, matching the oxygen output of 4.7 fir trees per m². Formaldehyde Removal: 23.5% higher efficiency than national standards | 84.1% long-term purification
- ▶ **Dual Sustainable Gains**
 - ① Clean Air Impact: Purifies air for 320,000 people daily—equivalent to refreshing 0.35 Bird's Nest Stadiums
 - ② Carbon Asset Value: Adds 2073 USD/year in carbon credits (based on 2025 market rates)

Decoding Ecological Impact

[When a building's facade uses 10,000m² of PHOMI stone]

1. Carbon Reduction Impact

- Lifecycle carbon footprint: Only 10,200 kg CO₂e
- 73,000 kg CO₂e less than natural stone (equivalent to 3,317 mature trees' annual carbon absorption)
- 209,000 kg CO₂e less than traditional tiles (equivalent to the annual emissions of 95 SUVs)

2. Ecological Breathing Value

- Continuously releases 4.97 × 10¹¹ negative ions per second = the purification of 17 football field-sized pine forests
- Provides a 3.2 km thick "natural air vitamin" shield for the building

3. Environmental Equivalency

- Equivalent to creating 4.2 square kilometers of tropical rainforest's annual carbon absorption
- Equivalent to 1,248 commercial air purifiers running for 30 years, providing daily negative ions for 18,720 residents

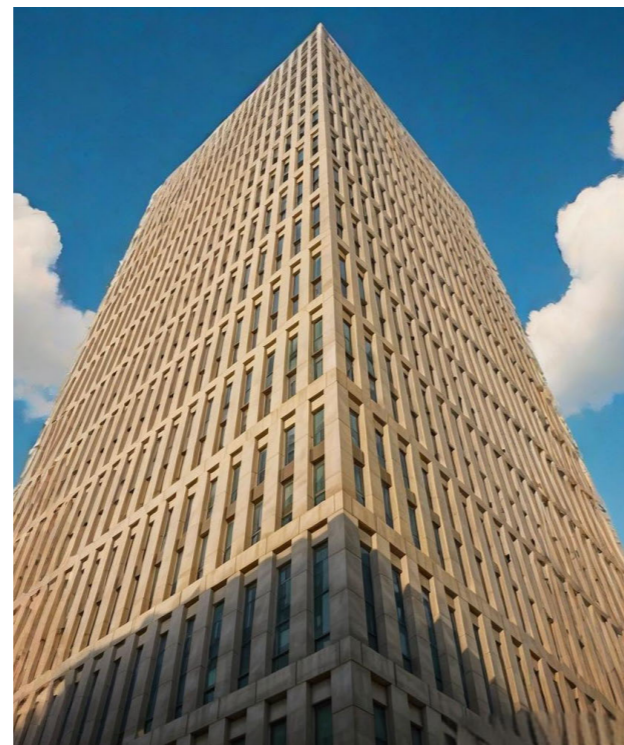

Storefront Facade · Visualized Eco-Benefits

[1,000m² PHOMI Stone Application]

- ▶ Carbon Footprint: Just 1.02 tons CO₂e, cutting 19 tons of quarrying emissions—equal to planting 86 mature ginkgo trees
- ▶ Air Quality Boost: 47 × WHO standard in negative ions, extending customer stop time by 28%

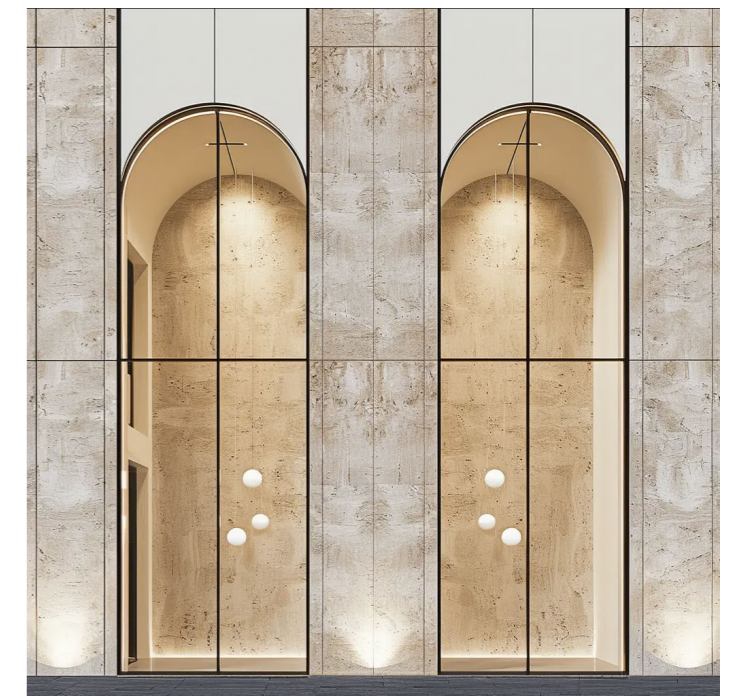



Negative Ion Series

Each square meter of PHOMI stone rebuilds the harmony between architecture and nature.



Home Eco Cube [250m²]

Carbon Reduction

- ▶ 255kg CO₂ lifecycle footprint
- ≈ 27 fir trees' carbon absorption for 30 years
- ≈ Offsets 8.3 cars' annual commute emissions

Healthy Air

- ▶ 1.24 × 10¹⁸ negative ions/sec
- ≈ Transforms your home into an 80m-thick pine forest oxygen zone
- ≈ Provides 16.5x WHO's clean air standard for a family of four

Impact at a Glance

- ✓ In a 40m² living room, every 10 minutes of breathing provides the same amount of negative ions as a 1-hour forest walk.
- ✓ Compared to traditional covering materials, saves 1.1KW.h A/C consumption every day for your home.

Eco Living, Everywhere

From kitchen countertops to balcony walls, every square meter contributes to the planet's breathing rhythm.



Precise Carbon Reduction for Commercial Spaces

[1,000 m² of eCoverings used in commercial spaces]

Carbon Reduction Impact:

73 tons CO₂e saved over the lifecycle = annual carbon absorption of 322 mature camphor trees

Air Regeneration System:

Releases 4.97 billion negative ions per second = 0.004 mature fir trees' carbon absorption per square meter of wall

Environmental Contributions:

- ① Carbon Asset Growth: Annual reduction of 72.98 tons = Worth 583.84 USD/year (based on 2025 carbon price of 8 USD/ton)
- ② Air Quality Improvement: Purifies air for 91,000 people daily (meeting WHO standards of 30m³ per person/day)
- ③ Business Carbon Offset: Offsets emissions of 31 fuel-powered vehicles annually (based on national standards of 2.36 tons CO₂ per vehicle/year)

Micro-Space Eco Revolution

[30m² Eco-Space Impact]

Air Purification

- ▶ 1.49 billion negative ions/sec = 120m² bamboo forest
- ▶ 4.5m³ medical-grade clean air/min

Carbon Reduction

- ▶ 30.6kg CO₂ lifecycle footprint ≈ 1.5 poplar trees' annual absorption
- ▶ 2,189kg less CO₂ vs. stone, saving 300kg coal

Daily Benefits

- ✓ Offsets 7.3 fuel cars' 10km emissions
- ✓ Restores 156m² rainforest
- ✓ Equals 37 ICU air purifiers running nonstop

[15m² Eco-Space Impact]

A 15m² wall in a dressing room delivers 8 hours of fresh air, equivalent to a 2km walk through a pristine forest.



A Data-Driven Green Retail Space Revolution

1000m² Coverings= Advanced Eco-Tech Matrix

Carbon Reduction Innovation

- ▶ Carbon emission: 1.02 kg/m² (98.6% lower than stone)
- ▶ Total carbon reduction: 729,800 kg CO₂ = Sequestered carbon of 3,317 30-year-old camphor trees

Smart Air System

- ▶ 4.97 billion negative ions/second released continuously (1m² = equivalent to 4.2 fir trees' purification)
- ▶ Formaldehyde removal efficiency 23.5% above national standard | Long-lasting purification: 84.1%

Environmental Impact

- Carbon Asset: 729.8 tons of carbon reduced annually = Carbon revenue of 5949 USD (2025 carbon price 8 USD/ton)
- Healthy Breathing Model: Provides clean air for 91,000 people daily (WHO standard: 30m³/person · day)
- Low-carbon Impact: Equivalent to offsetting the annual emissions of 309 fuel-powered cars

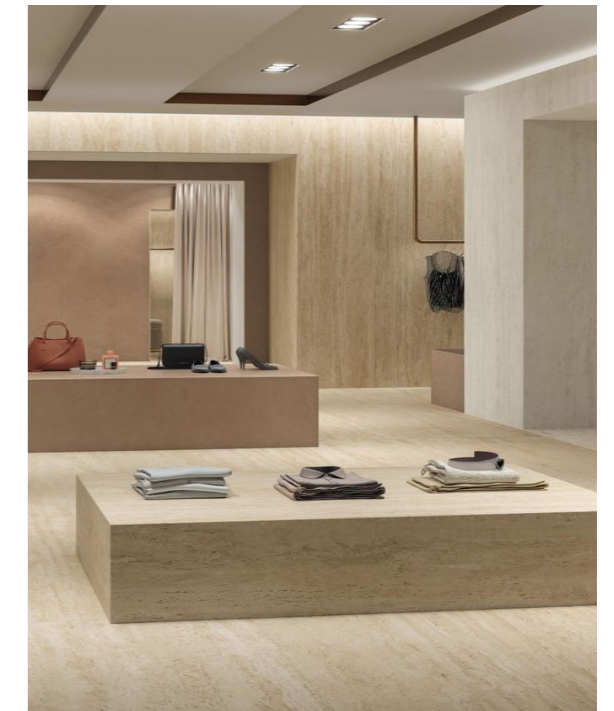

eCovering & Negative Ion Series Installation Method

DIY Series

Only for interior dry wall and floor application

≤1200x600mm product back side

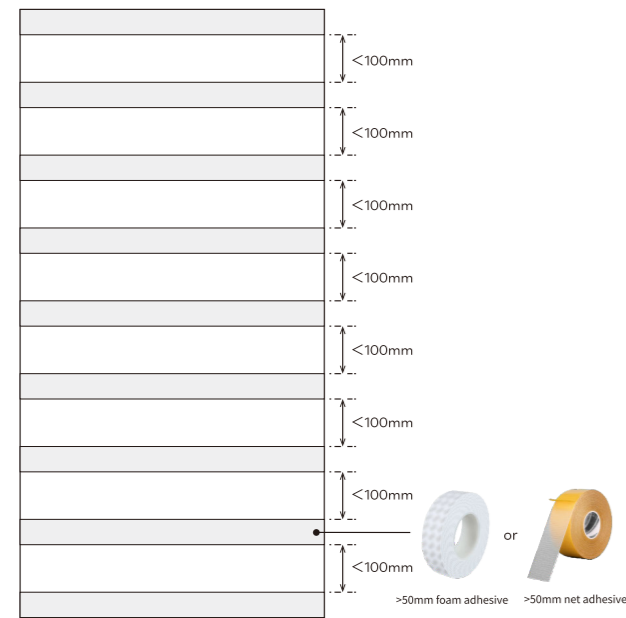

Magnet sticking

Only for interior dry wall and floor application

≤1200x600mm product back side

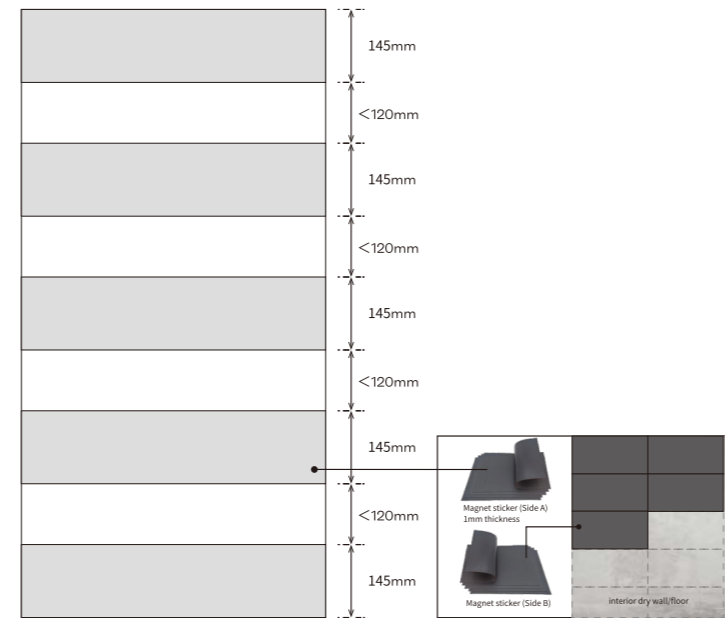

Dry-hanging system

Commonly used for exterior walls

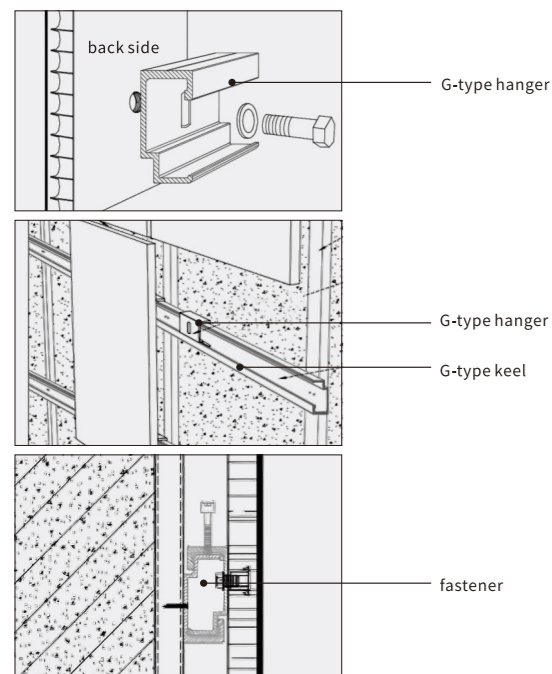

Wet installation system

Suitable for both interior & exterior

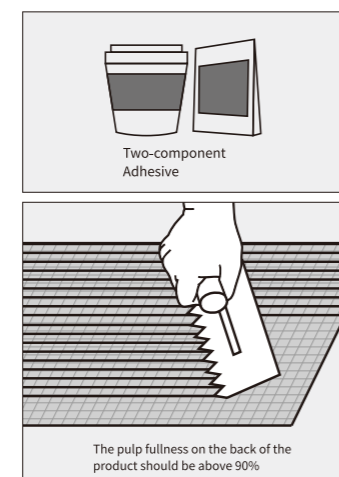

Note: For interior applications in bathrooms or other wet areas, wet-pasting installation is required.

eSolarFacade & eDisplay Installation Method

Use a laser rangefinder and digital level for wall positioning. Secure the custom keel with an impact drill using mechanical anchoring. Align the panel slots with the keel for initial fixation, then fine-tune and reinforce with specialized connectors to ensure precision and efficiency.

1 Attach/Secure the aluminum brackets to the back of the honeycomb panel with bolts and nuts.

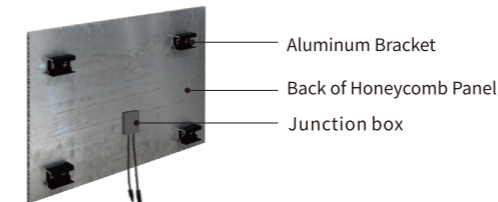

2 Secure the aluminum rail with expansion bolts to the solid wall. Insert the aluminum brackets of honeycomb panel into the aluminum rail on the solid wall, then secure the brackets to the rail with screws (bolts and nuts).

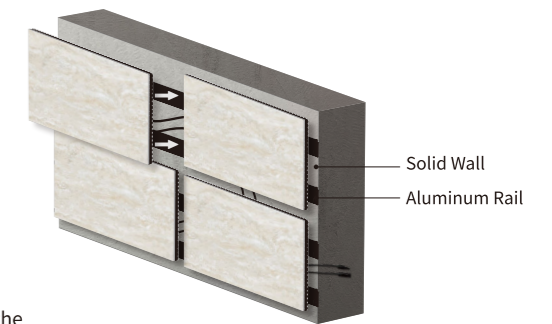

Installation and Maintenance

1. Cleaning: After acceptance, the frequency of cleaning should be determined based on the level of wall contamination, with a minimum of once a year. Use hand soap mixed with tap water, and avoid using organic solvents.

2. Curtain wall inspection and maintenance:

- A comprehensive inspection of the curtain wall should be conducted every five years, including the panels, sealing strips, and sealants.
- Tighten any loose bolts, and for corroded connectors, remove rust and repaint or replace them.
- Loose or damaged panels should be repaired or replaced.
- Sealants and sealing strips that have fallen off or are damaged should be repaired or replaced.
- Damaged components or connectors should be replaced or reinforced if the anchoring is loose.
- Regularly check the drainage system, and clear any blockages.
- Any loose or damaged hardware should be replaced.

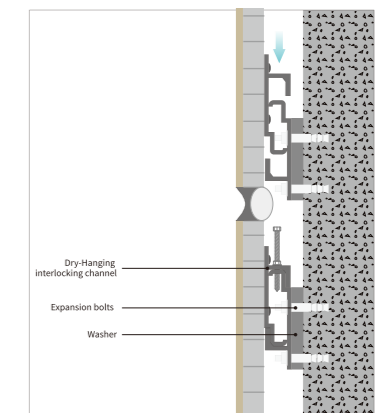

Schematic diagram of Dry-Hanging

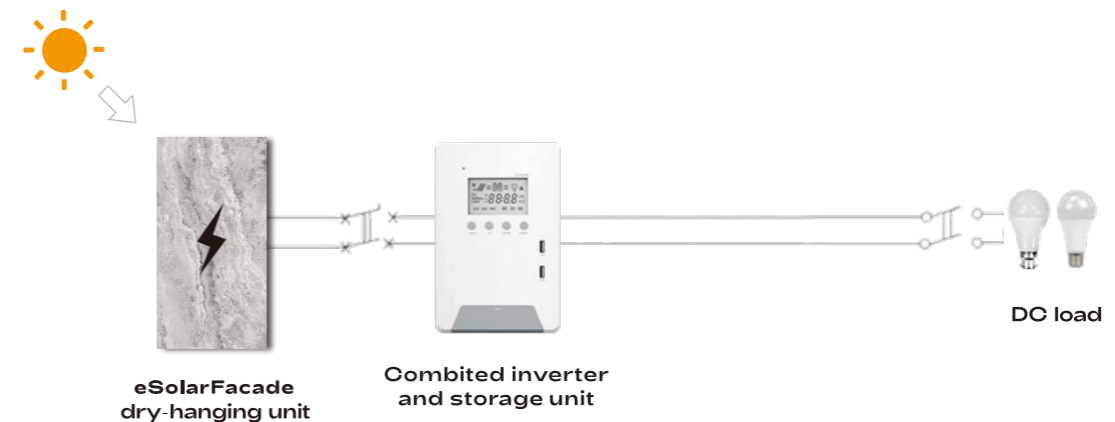

eSolarFacade off-grid energy storage system

Civil eSolarFacade: When purchasing civil eSolarFacade, Phomi will provide you with (extra charge) an off-grid energy storage system, including storage batteries, controllers, and inverters, based on your order quantity. Please consult your local Phomi Agency for the pricing of eSolarFacade and the energy storage system.

Commercial eSolarFacade: The installation of the electrical components should proceed in sync with the setup of the curtain wall, strictly following the electrical design drawings and the relevant design and construction standards.

Functional Model Structure

Main category	eSolarFacade eDisplay eCovering	If it is eCovering, omit this section and proceed directly to the texture.
Texture	Rome Travertine 3.0 Rome Travertine 4.0 Oceanic Travertine 3.0 Oceanic Travertine 4.0 Marble 3.0 Marble 4.0 Sandstone 3.0 Sandstone 4.0	This code is a must for every item. If it is eDisplay and eSolarFacade generation code is not required.
Installation	SA. (Self Adhesive) MG. (Magnetic) AH. (Aluminum honeycomb. If there is a number after AH, it is the thickness of honeycomb.) AP. (Aluminum panel) SF. (Steel frame) FC. (Fibreglass cement)	This code can be null if it is by wet paste.
Extra function	B. (with insulation) N. (with negative oxygen ion) M. (with anti-mold/bacteria coating) G. (Glossy and higher anti-stain coating)	This code can be null if it is normal coating.
Technical Specification	20V. (with 20mm vacuum insulation) 30V. (with 30mm vacuum insulation) 50V. (with 50mm vacuum insulation) 50R. (with 50mm rockwool insulation) P25. (P2.5 for eDisplay) P40. (P4.0 for eDisplay) P66. (P6.6 for eDisplay)	This code can be null.
Color	Aegean White Moonlight Sunis White Australia Orange Cloud Andes White White Sesame BN02	This code is a must for every item.

Example

eCovering	Rome Travertine 3.0 Aegean White
eSolarFacade	eSolarFacade Rome Travertine AP.30V.Aegean White
eDisplay	eDisplay Rome Travertine AP.20V.P66.Aegean White
Negative Ion Series	Rome Travertine 3.0 N.Aegean White

material science
that shapes
the future